

Ferramenta Hardware	Componenti Components								
Serratura (H) Lock (H)	n°1		Base e cappello (A) Base and top (A)		Fianco DX-SX (B) R-L side (B)		Retro (C) Back panel (C)		Ripiano (D) Shelf (D)
Reggipiano (J) Shelf support (J)	n°4		Anta (E) Door (E)		Cassettiera (F) Chest of drawers (F)		Top (G) Top (G)		
Maniglie (I) Handles (I)	n°4								

Bariotto 14x14 (L) Barrel 14x14 (L)	n°24	Vite (W) Screw (W)	n°6
Grano 8x8 (M) Threaded screw 8x8 (M)	n°24	Cerniera (X) Hinge (X)	n°2
Tirante 7x33 (N) Tie-rod 7x33 (N)	n°24	Basetta (Y) Hinge base (Y)	n°2
Spina 8x30 (O) Wooden pin 8x30 (O)	n°28	Chiave esagonale Hexagonal key	n°1
Bullone 4x25 (P) Bolt 4x25 (P)	n°6		
Ruote (Q) Castors (Q)	n°4		
Vite di giunzione 5x27 (S) Junction Screws 5x27 (S)	n°4		
Bullone 6x30 (Z) Bolt 6x30 (Z)	n°4		

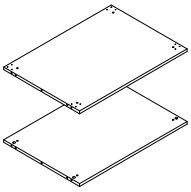
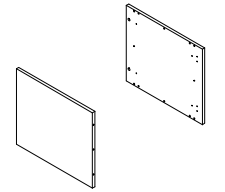
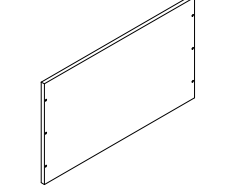
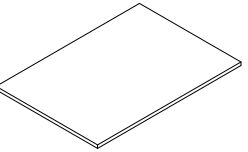
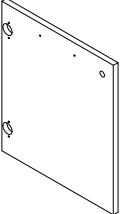
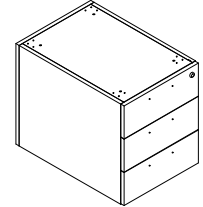
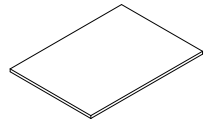
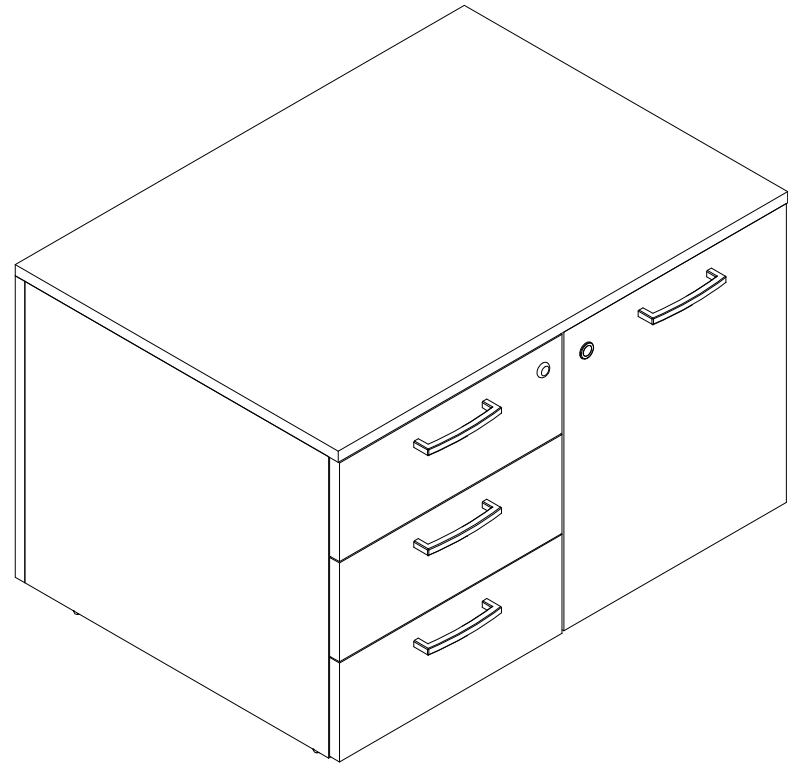
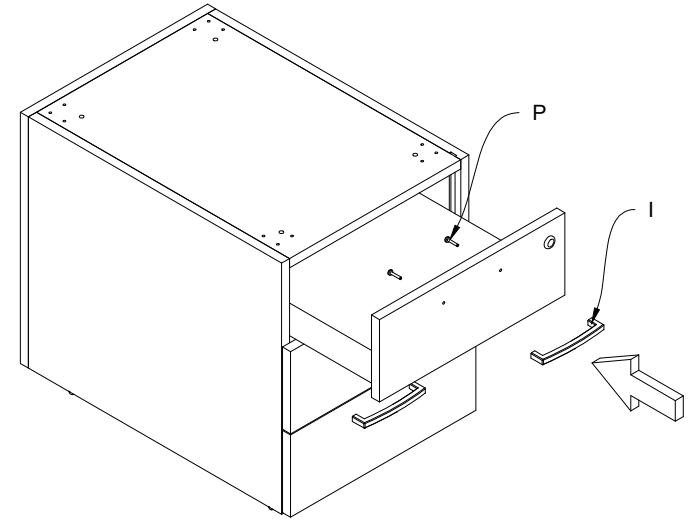
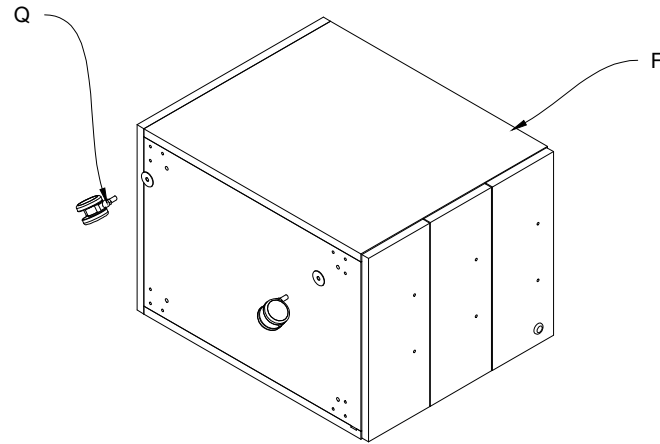
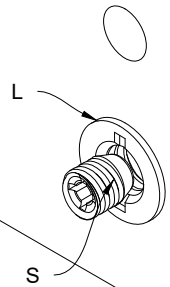

Fig.1 Serraggio dei grani (M) nei barilotti (L)  
Fig.1 Tighten the threaded screws (M) in the barrels (L)

1) Ruotare la cassettera (F) in modo che si possano inserire le ruote (Q) nella base.  
1) Rotate the chest of drawers (F), insert the castors (Q) in the base.

2) Inserire le maniglie (I) nei frontali della cassettera tramite i bulloni (P)  
2) Insert the handles (I) in the fronts of the chest of drawers by means of the bolts (P)



3) Poggiando un fianco (B) a terra, fissare base (A), cappello (A) e l'altro fianco (B) tramite le spine (O) e i tiranti (N)  
3) Rotate the chest of drawers on one side (B), fasten the base (A), top (A) and the other side (B) by means of the wooden pins (O) and tie-rods (N)

4) Inserire il retro (C) tramite le spine (O) e i tiranti (N)  
4) Insert the back panel (C) by means of the wooden pins (O) and tie-rods (N)

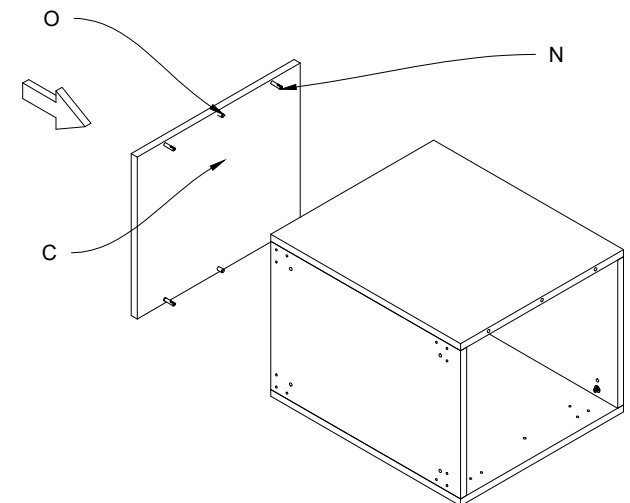
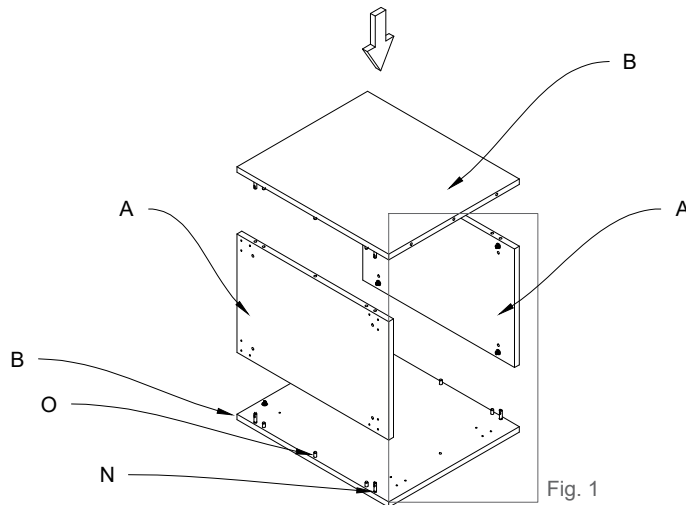
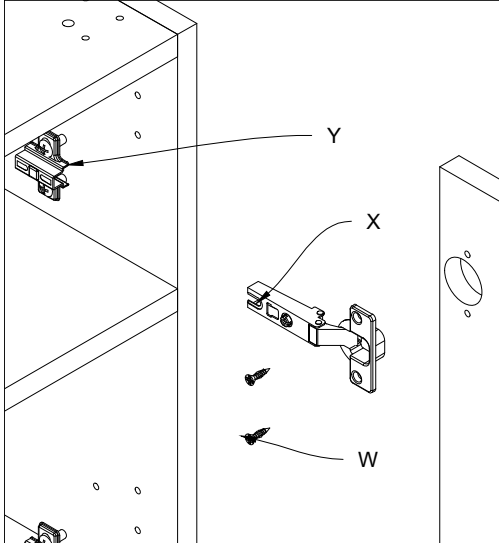
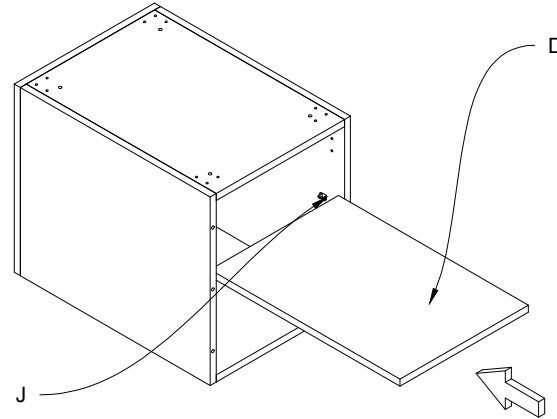

Fig. 1

Fig.1 Inserimento delle basette (Y) e delle cerniere (X) tramite le viti (W)  
Fig.1 Insert the hinge bases (Y) and hinges (X) by means of the screws (W)



5) Inserire il ripiano (D) nella cassa tramite i reggipiani (J).  
5) Insert the shelf (D) in the box by means of the shelf supports (J)



6) Inserire l'anta (E) tramite le basette (Y), le cerniere (X) e le viti (W)  
6) Insert the door (E) by means of hinge bases (Y), hinges (X) and screws (W)

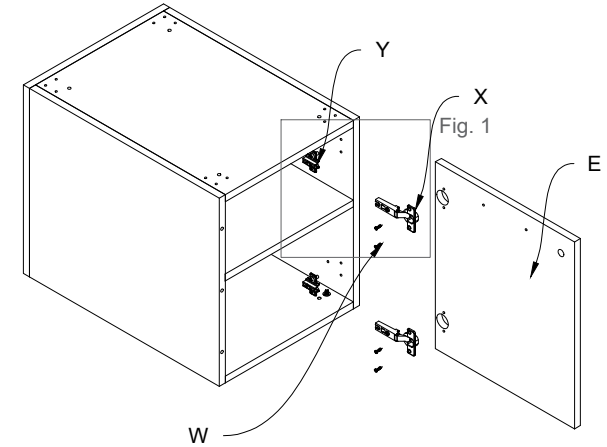
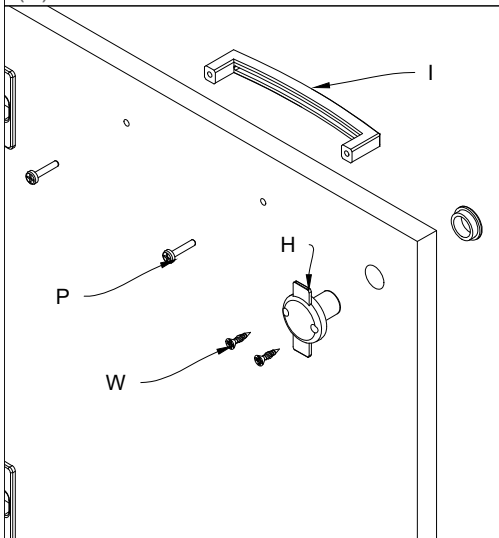
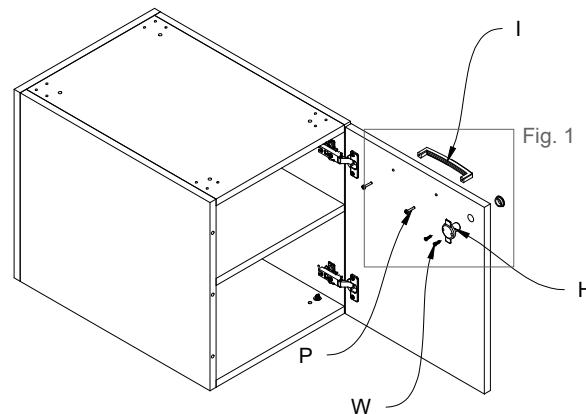

Fig.2 Inserimento della maniglia (I) e della serratura (H) tramite viti (W) e bulloni (P)  
Fig.2 Insert the handle (I) and lock (H) by means of the screws (W) and bolts (P)



7) Inserire la maniglia (I) e la serratura (H) tramite le viti (W) e i bulloni (P)  
7) Insert the handle (I) and lock (H) by means of the screws (W) and bolts (P)



8) Unire i vari moduli tramite le viti di giunzioni (S) utilizzando l'apposita preforatura  
8) Unite the units by means of the junction screws (S), use the pre-drilled holes

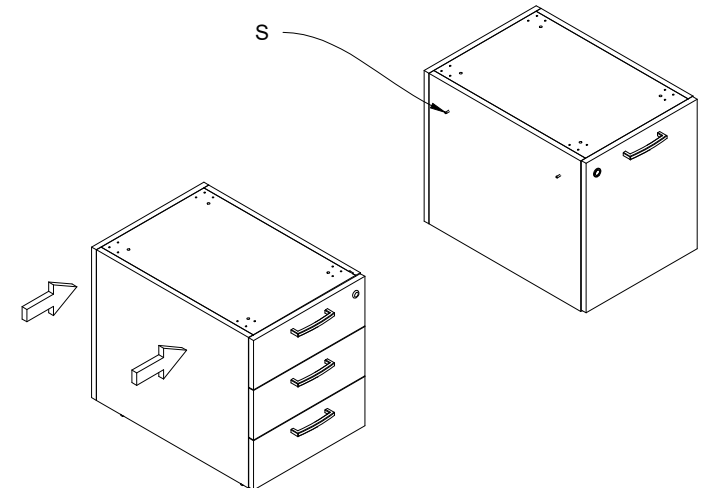

Fig.1 Unire il top (G) con il modulo tramite i bulloni (Z).  
Fig.1 Unite the top (G) to the unit by means of the bolts (Z)

6) Inserire il top (G) con le viti (Z) forandolo secondo l'esigenza utilizzando l'apposita preforatura  
6) Fasten the top (G) by means of the screws (Z), use the pre-drilled holes

