

# Schema di montaggio Assembly diagram

Ferramenta Hardware	Componenti Components								
Bullone da 6x20 (V) 	Bolt 6x20 (V) <b>n°4</b>		<b>Staffe (A)</b> L shaped brackets (A)		<b>Modesty in metallo (B)</b> Metal modesty panel(B)				
Bullone da 6x16 (Z) 	Bolt 6x16 (Z) <b>n°4</b>								
Chiave esagonale 	Hexagonal key <b>n°1</b>								

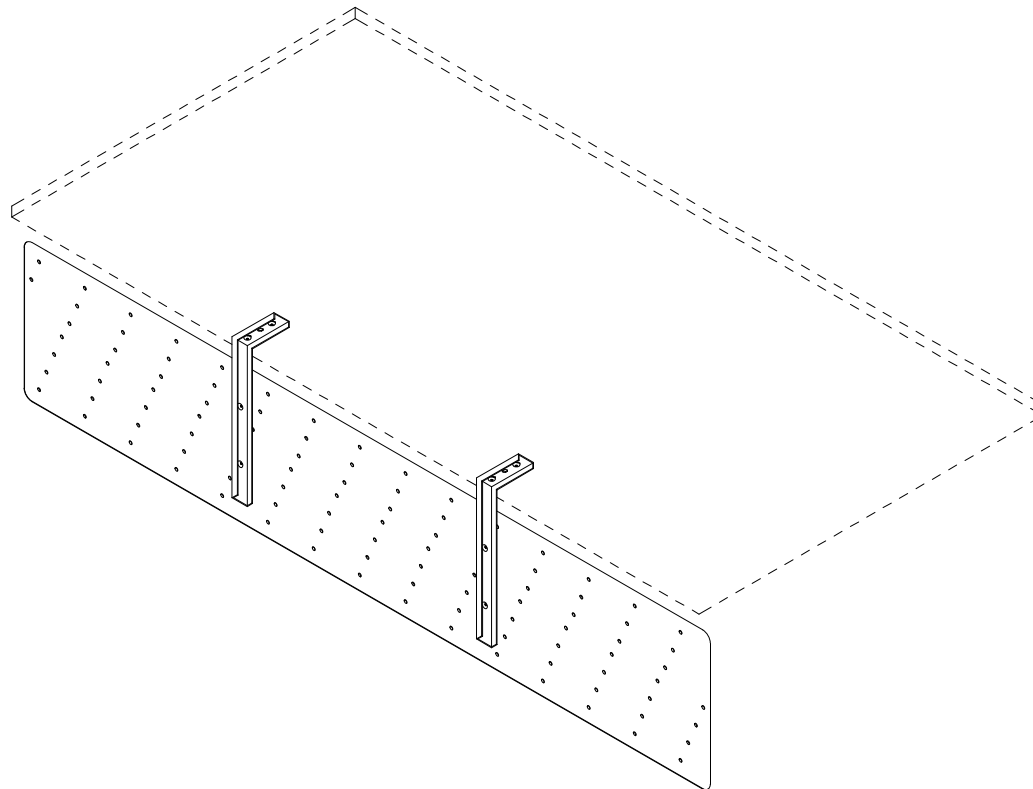

**Fig.1 Unione delle staffe (B) al piano tramite i bulloni (Z)**  
**Fig.1 Fasten the "L" shaped brackets (B) to the top by means of the bolts (Z)**

**1) Inserire le staffe (B) nel piano ed inserire i bulloni (Z) attraverso gli appositi fori**  
**1) Insert the "L" shaped brackets (B) in the top, insert the bolts (Z) in the pre-drilled holes**

**2) Inserire il modesty in metallo (A) nelle staffe (B) attraverso i bulloni (V)**  
**2) Insert the metal modesty panel (A) in the "T" shaped brackets (B) by means of the bolts (V)**

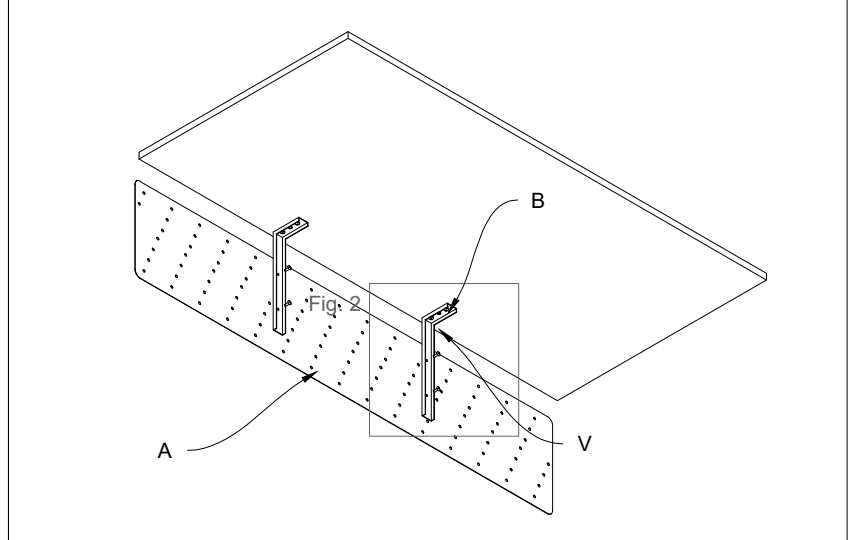
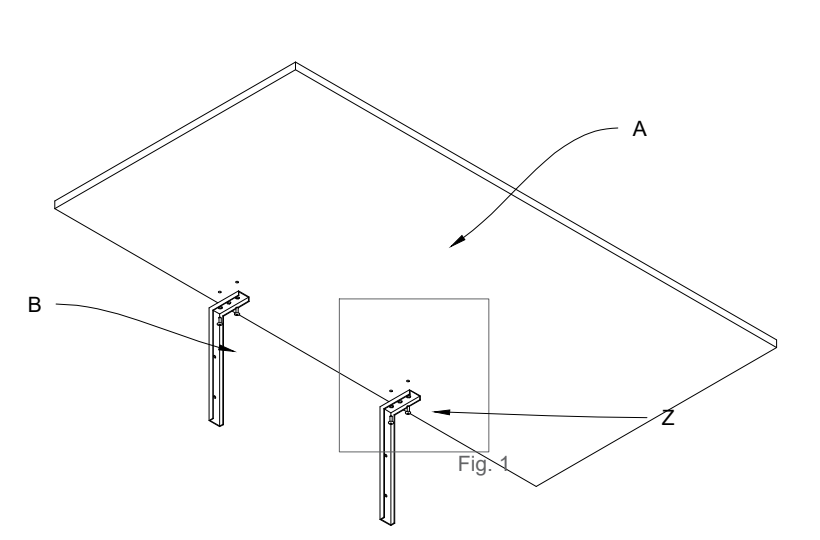
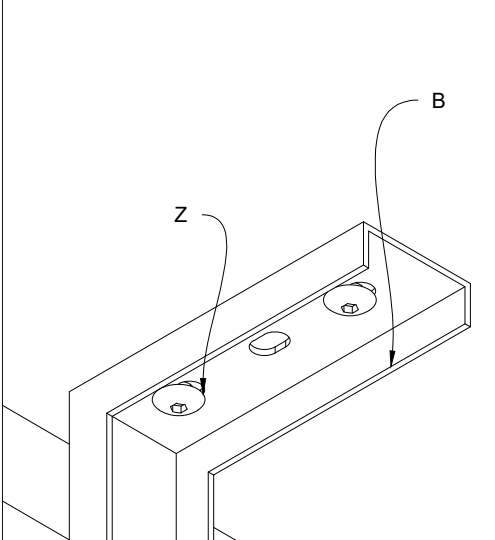

**Fig.2 Unione del modesty in metallo (A) nelle staffe (B) tramite i bulloni (V)**  
**Fig.2 Unite the metal modesty panel (A) to the "L" shaped brackets (B) by means of the bolts (V)**

