

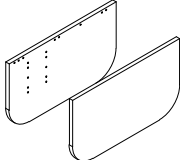

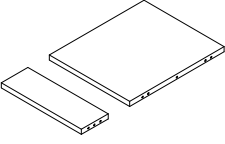

Ferramenta Hardware	Componenti Components							
Feltri 	Felt pads n°4	Fianchi (A) Sides (A) 		Piani (B) Tops (B) 	Fianchi del portariviste (C) Magazine rack sides (C) 		Base del portariviste (D) Magazine rack base (D) 	
Spina in legno 8x30 (T) 	Wooden pin 8x30 (T) n° 31							
Barilotto 14x14 (U) 	Barrel 14x14 (U) n°16							
Tirante 7x33.5 (V) 	Tie-rod 7x33.5 (V) n°16							
Grano 8x8 (Z) 	Threaded screw 8x8 (Z) n°16							

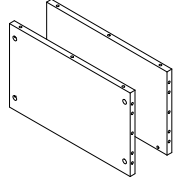
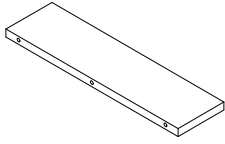
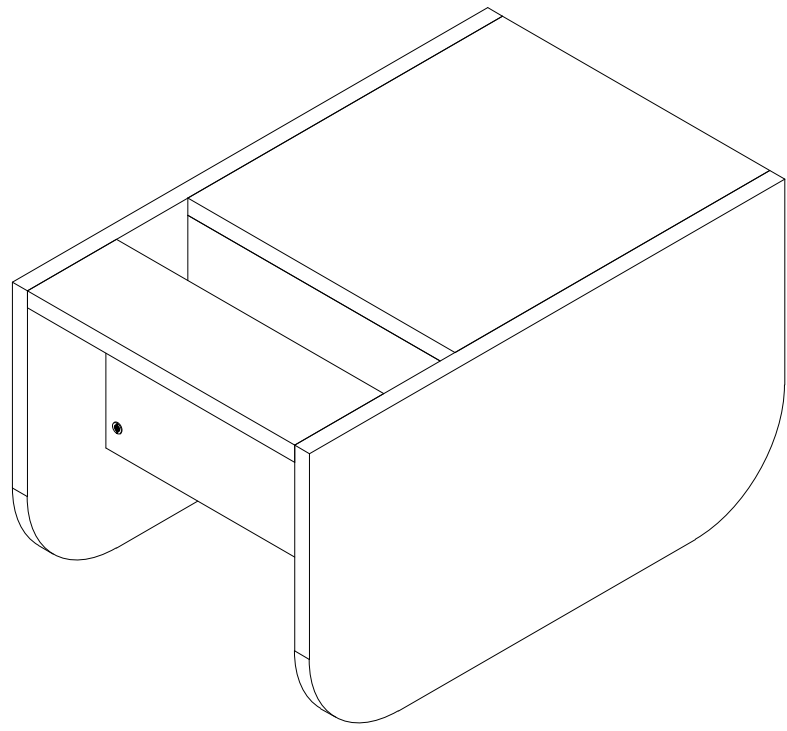
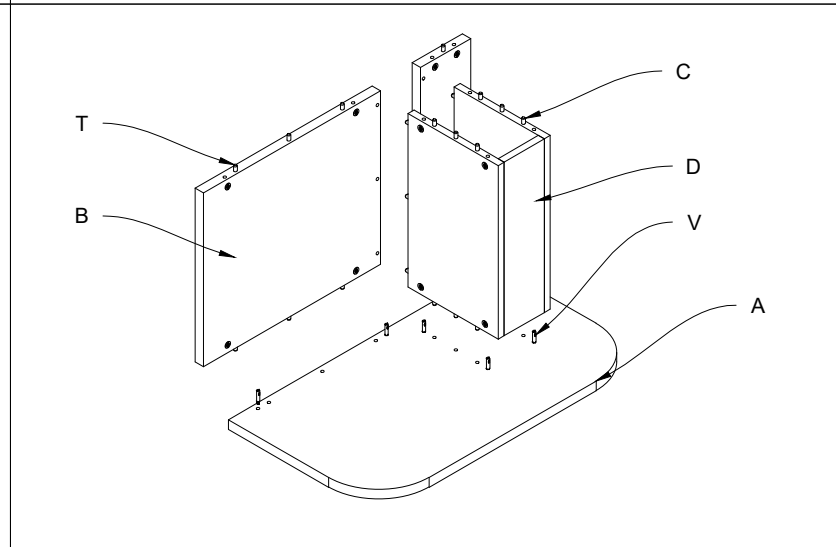
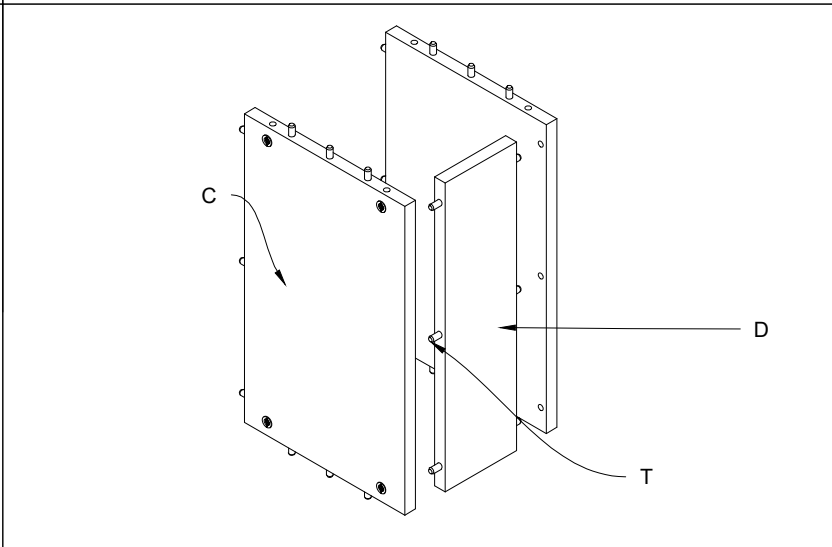
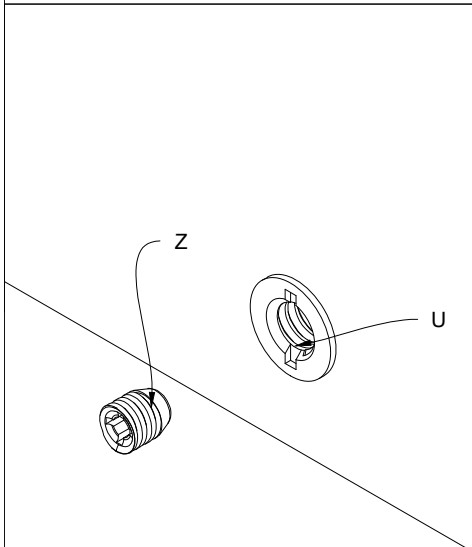

Fig.1 Serrare i grani (Z) nei barilotti (U).
Fig.1 Tighten the threaded screws (Z) in the barrels (U).

1) Inserire le spine (T) nei fianchi del portariviste (C) e nella base del portariviste (D) e unire le parti.
1) Insert the wooden pins (T) in the magazine rack sides (C) and base (D) and unite the two parts.

2) Unire i piani (B) e la zona del portariviste (C,D) in un fianco (A) tramite le spine (T) e i tiranti (V)
2) Unite the tops (B) to the magazine rack sides (C) and base (D) in one side (A) by means of the wooden pins (T) and tie-rods (V).



3) Unire il secondo fianco (A) alla struttura costruita in precedenza. Infine serrare i grani (Z) nei barilotti (U).
3) Unite the second side (A) to the constructed structure, tighten the threaded screws (Z) in the barrels (U).

