









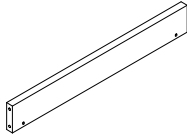
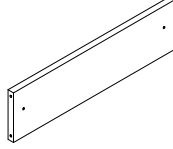

Schema di montaggio Assembly diagram

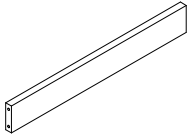
Ferramenta Hardware	Componenti Components								
Chiave esagonale Hexagonal key	n°1		Ripiano strutturale (A) Structural shelf (A)		Fianchi (B) Sides (B)		Elemento 1 (C) Element 1 (C)		Elemento 2 (D) Element 2 (D)
Spina in legno 8x30 (T) Wooden pin 8x30 (T)	n° 124		Ripiano mobile (E) Adjustable shelf (E)		Base (F) Base (F)		Fianco intermedio (G) intermediate side (G)		
Barilotto 14x14 (U) Barrel 14x14 (U)	n°24								
Tirante 7x33.5 (V) Tie-rod 7x33.5 (V)	n°24								
Grano 8x8 (Z) Threaded screw 8x8 (Z)	n°24								
Feltri Felt pads	n°6								

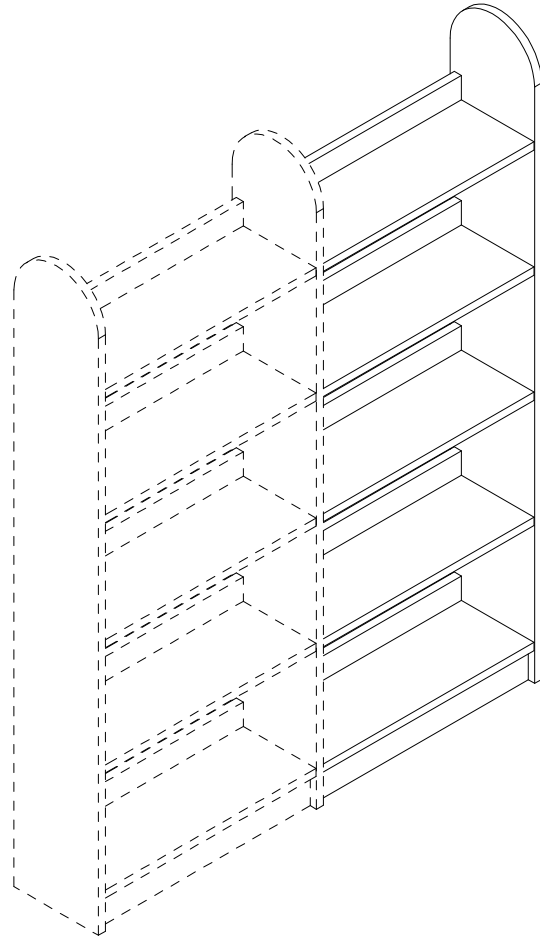
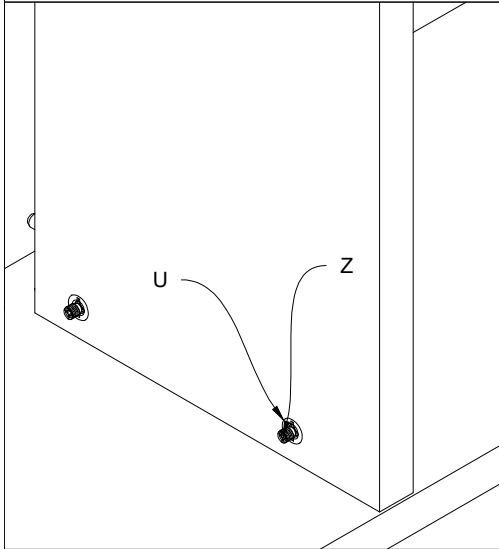
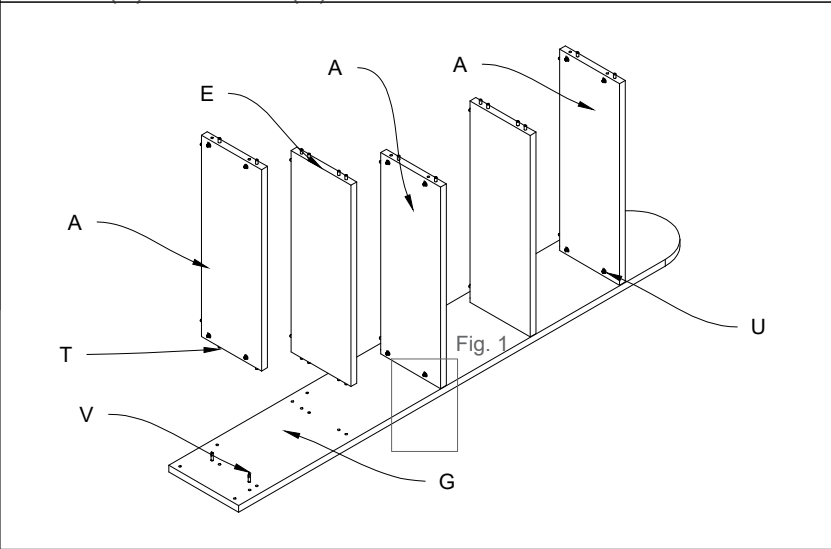

Fig.1 Serrare i grani (Z) nei barilotti (U).
Fig.1 Tighten the threaded screws (Z) in the barrels (U).



1) Posizionare il fianco (G) sul pavimento inserendo il ripiano mobile (E) e quello strutturale (A) tramite spine (T) tiranti (V) e barilotti (U).
1) Position the side (G) on the floor, insert the structural and adjustable shelves (A and E) by means of the wooden pins (T), tie-rods (V) and barrels (U).



2) Posizionare l'elemento 1 (C), l'elemento 2 (D) e la base (F) nel fianco (G) e nei ripiani (A e E) tramite le spine (T).
2) Position element 1 (C), element 2 (D) and the base (F) in the side (G) and shelves (A and E) by means of the wooden pins (T).

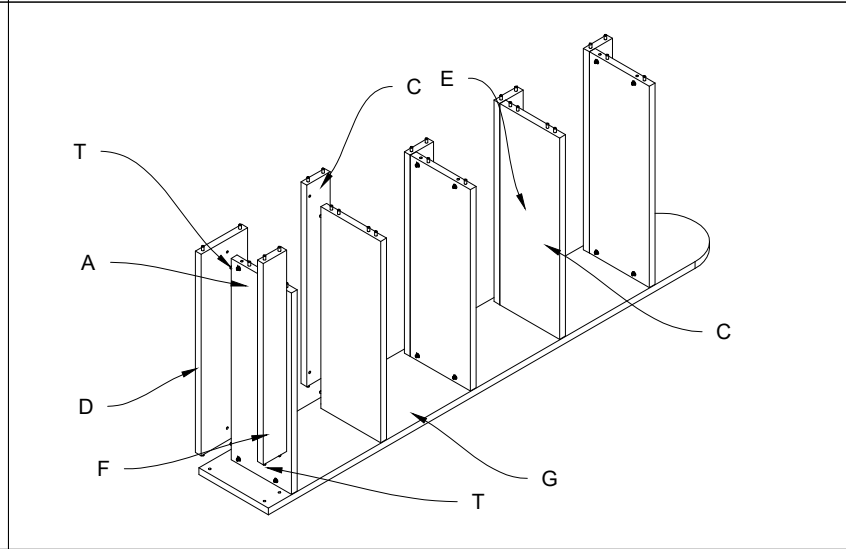
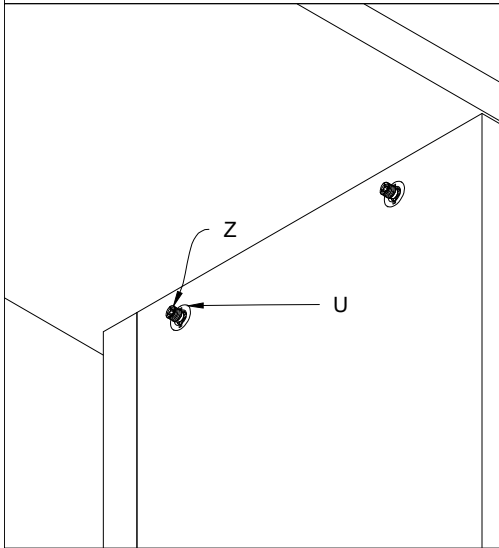
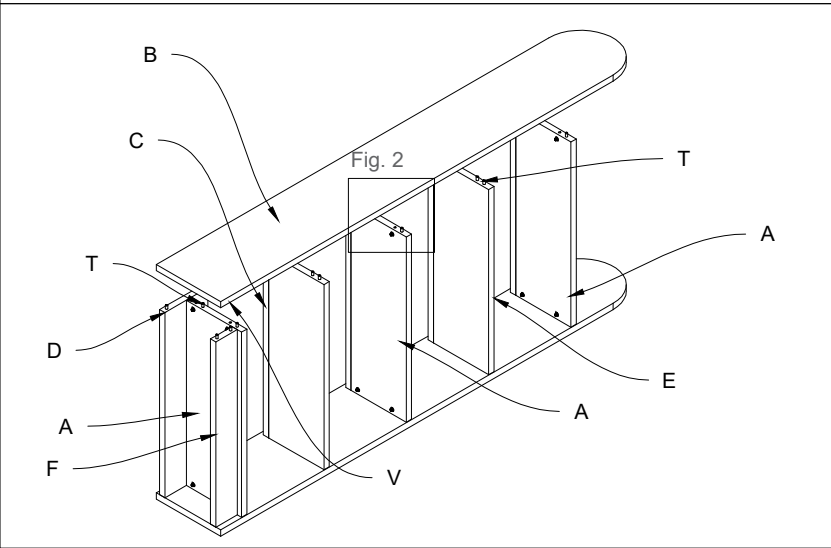

Fig.1 Serrare i grani (Z) nei barilotti (U).
Fig.1 Tighten the threaded screws (Z) in the barrels (U).



3) Unire il fianco (B) con i ripiani (A e E) gli elementi (C e D) e la base (F) tramite spine (T) e tiranti (V).
3) Unite the side (B) to the shelves (A and E), elements (C and D) and base (F) by means of the wooden pins (T) and tie-rods (V).



4) Ruotare la libreria e aggiungere i tiranti (V) nel fianco intermedio (G).
4) Rotate the bookcase and add the tie-rods (V) in the intermediate side (G).

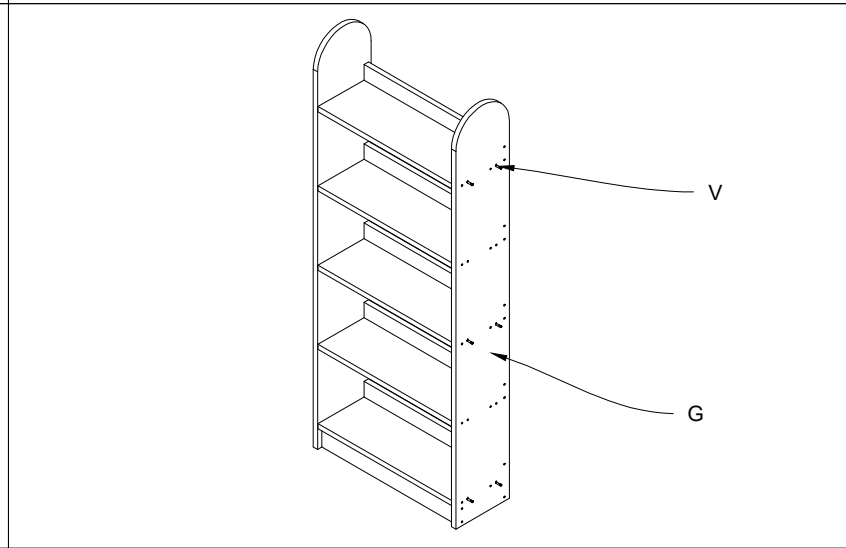
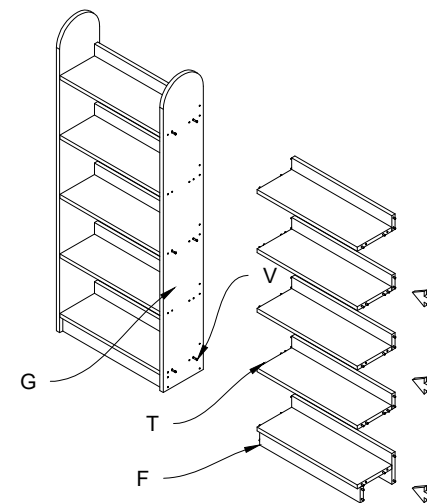
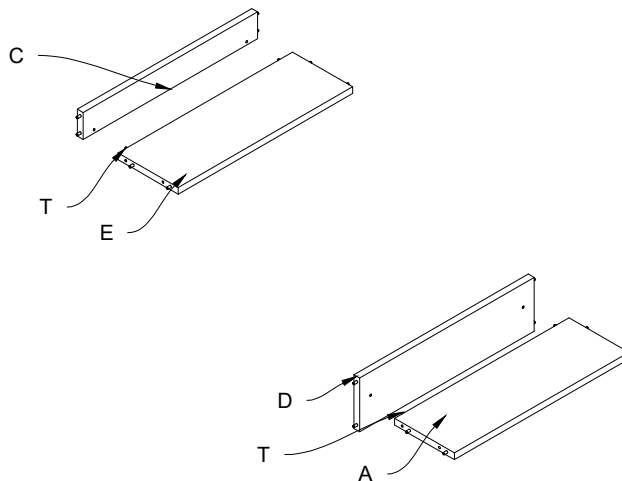
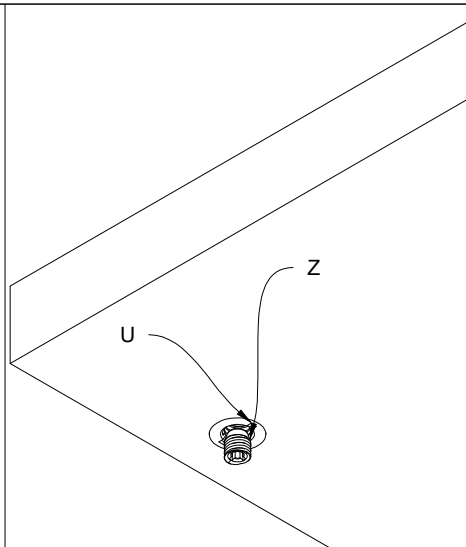

Fig.1 Serrare i grani (Z) nei barilotti (U).
Fig.1 Tighten the threaded screws (Z)
in the barrels (U).

5) Assemblare i ripiani (A e E) e gli elementi (C e D) con le spine (T)
5) Assemble the shelves and elements (C and D) by means of the
wooden pins (T)

6) Unire i ripiani montati e la base (F) al fianco intermedio (G) tramite
spine (T) e tiranti (V).
6) Unite the assembled shelves and base (F) to the intermediate side
(G) by means of the wooden pins (T) and tie-rods (V).



7) Unire il fianco (B) con i ripiani (A e E) gli elementi (C e D) e la base
(F) tramite spine (T).
7) Unite the side (B) to the shelves (A and E), elements (C and D) and
base (F) by means of the wooden pins (T).

