

Fig.1 Posizionare spine (S), barilotti(U), tiranti(V) nei fianchi(B e C)
Fig.1 Position the pins (S), barrels (U) and tie-rods (V) in the sides (B and C)

1) Posizionare le spine (S), i barilotti (U), i tiranti (V) e piedini (T) nei fianchi (B e C).
1) Position the pins (S), barrels (U), tie-rods (V) and feet (T) in the sides (B and C)

2) Posizionare i barilotti (U) nella traversa (D).
2) Position the barrels (U) in the cross panel (D)

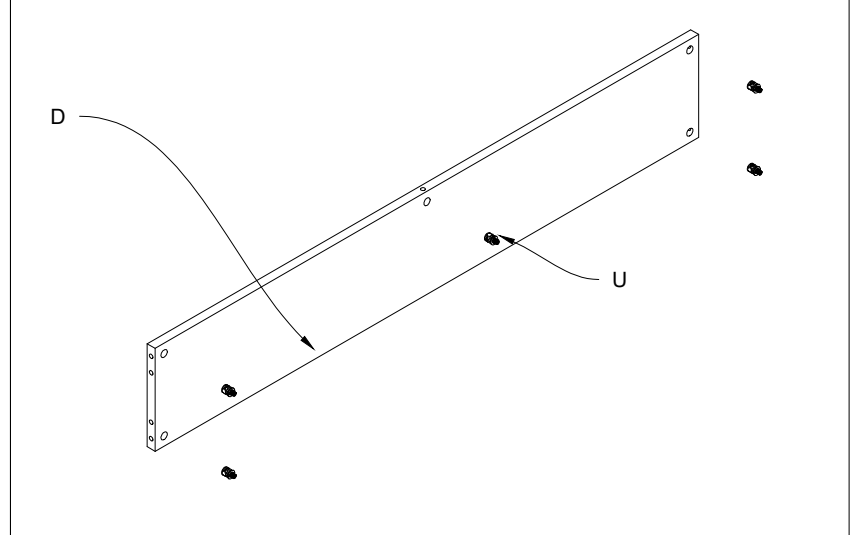
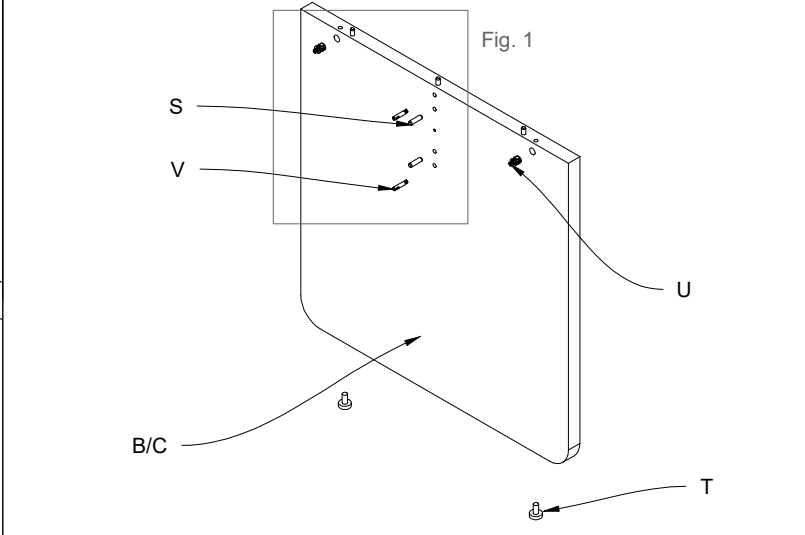
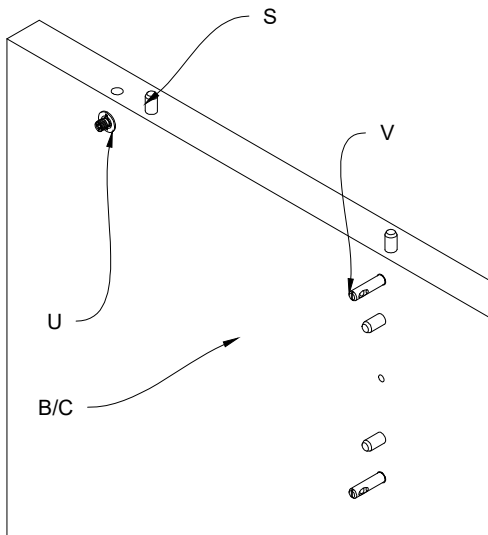

Fig.2 Posizionare i tiranti(V) nel piano (A)
Fig.2 Position the tie-rods (V) in the top (A)

3) Posizionare i tiranti (V) nel piano (A).
3) Position the tie-rods (V) in the top (A)

4) Unire il fianco (B) alla traversa laterale (E) tramite le spine (S).
4) Unite the side (B) to the lateral cross panel (E) by means of the wooden pins (S).

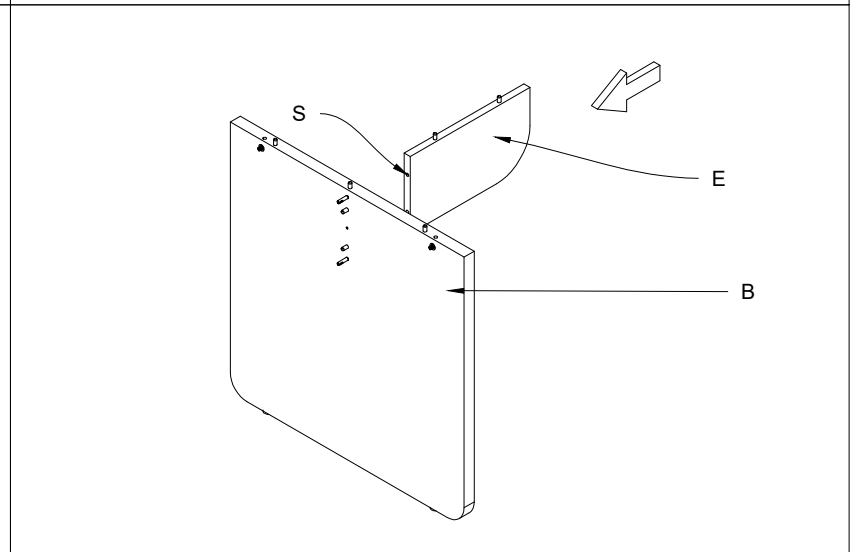
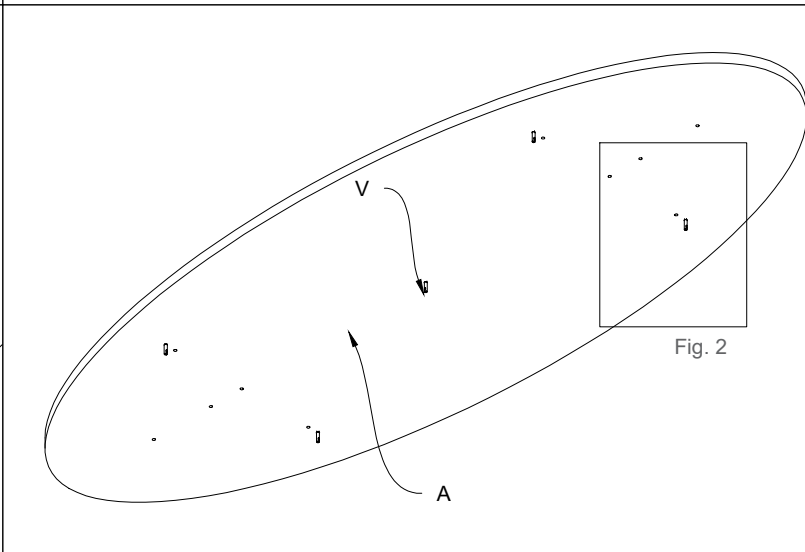
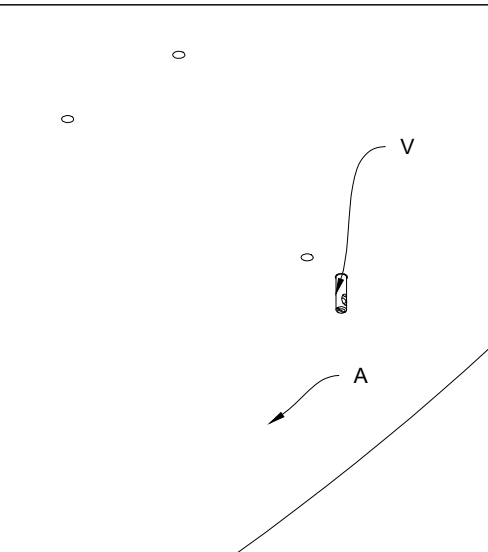
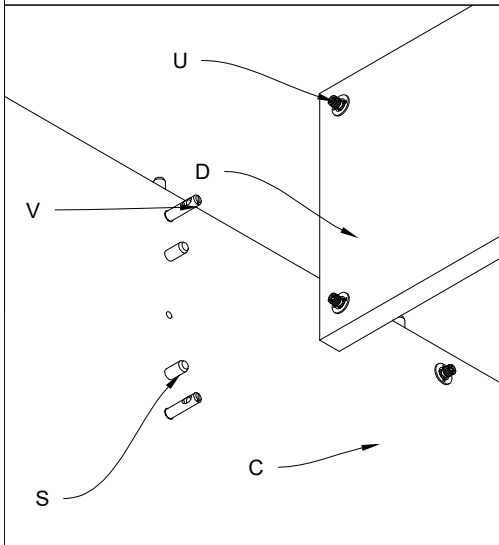
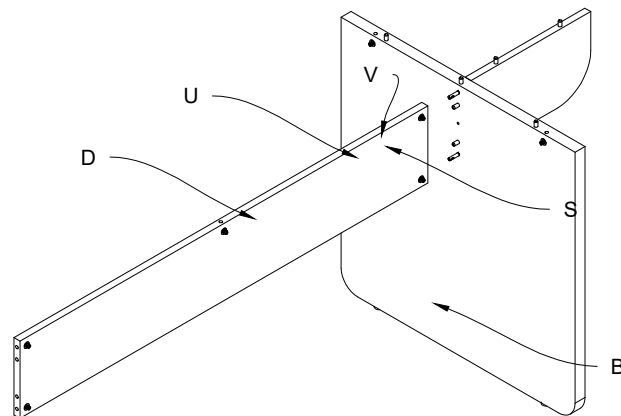

Fig.1 Unire la traversa (D) al fianco (C) tramite spine (S) tiranti (V) e barilotti (U).
 Fig.1 Unite the cross panel (D) to the side (C) by means of the wooden pins (S), tie-rods (V) and barrels (U).



5) Unire la traversa (D) con il fianco (B) tramite le spine (S) tiranti (V) e barilotti (U).
 5) Unite the cross panel (D) to the side (B) by means of the wooden pins (S), tie-rods (V) and barrels (U).



6) Posizionare e unire il fianco (C) alla traversa (D) e alla traversa laterale (E).
 6) Position and unite the side (C) to the cross panel (D) and lateral cross panel (E).

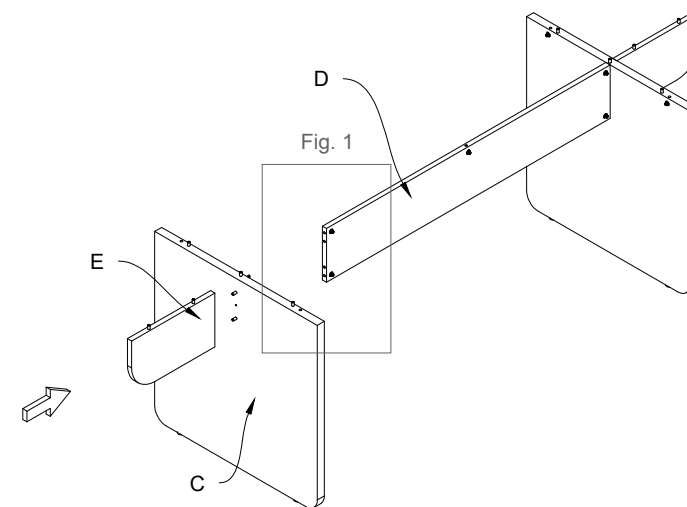
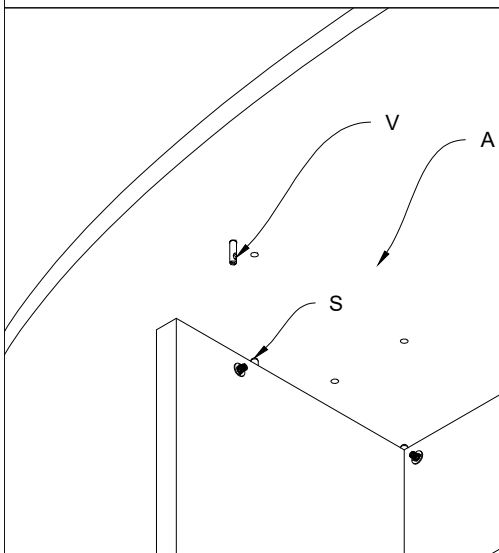
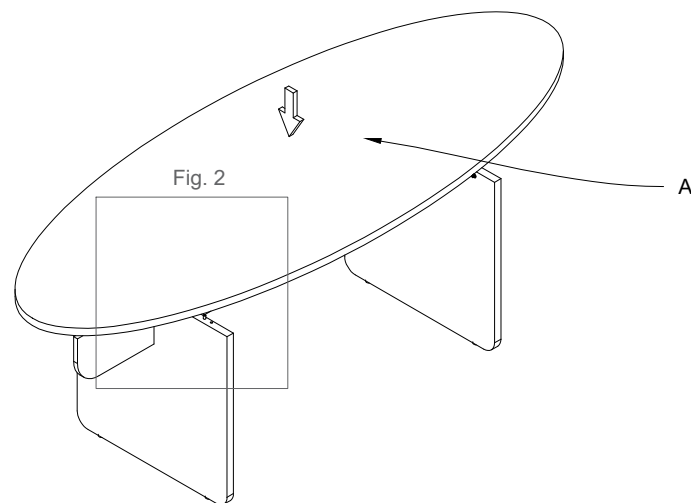

Fig.2 Unire il piano (A) alla struttura tramite spine (S) e tiranti (V).
 Fig.2 Unite the top (A) to the structure by means of the wooden pins (S) and tie-rods (V).



7) Unire il piano (A) alla struttura.
 7) Unite the top (A) to the structure.



8) Serraggio dei grani (Z) nei barilotti (U).
 8) Tighten the threaded screws (Z) in the barrels (U).

