









<p>Componenti Components</p>		<p>Schienale alto x1 (A) High backrest x1 (A)</p>		<p>Schienale medio x1 (A) Low backrest x1 (A)</p>		<p>Schienale basso x1 (A) Low backrest x1 (A)</p>		<p>Sedile x1 (B) Seat x1 (B)</p>
<p>SERIE SKY LEATHER SERIES</p>		<p>Colonna a gas x1 (C) Gas lift x1 (C)</p>		<p>Base a 5 razze x1 (D) 5 star base x1 (D)</p>		<p>Ruota D.65 x5 (E) Castors Diam. 65mm x5 (E)</p>		<p>Movimento (F) Movement (F)</p>



SK01 - SK02 - SK03



SK05 - SK06 - SK07



SK09 - SK10 - SK11



SK13 - SK14 - SK15

1) Estrarre lo schienale (A), il sedile e il movimento dalla scatola
 1) Extract the backrest (A), seat and movement from the box



2) Estrarre la base (D), la colonna a gas (C) e le ruote (E) dalla scatola
 2) Extract the base (D), gas lift (C) and castors (E) from the box

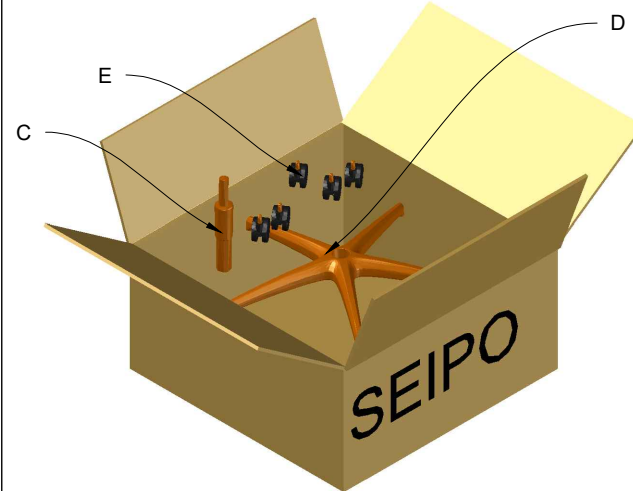

3) Inserire le ruote (E) nella base (D) fino a quando non si sente un click al fine di bloccarle.
 3) Insert the castors (E) in the base (D) until you hear a click for locking

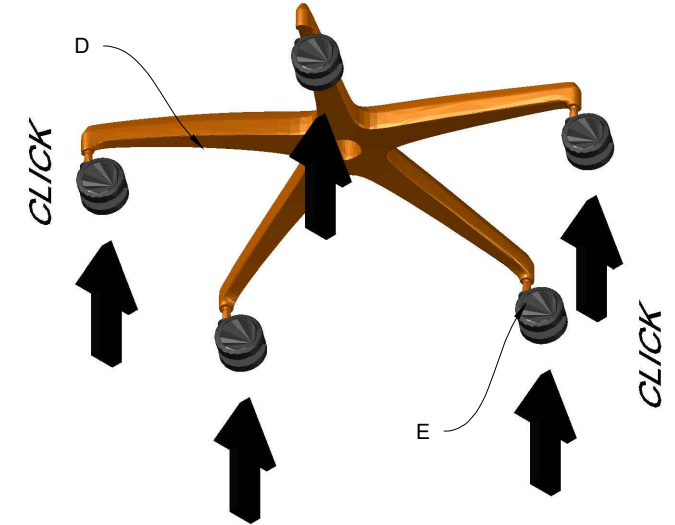

4) Inserire la colonna a gas (C) nel cono della base (D).
 4) Insert the gas lift (C) in the cone of the base (D)

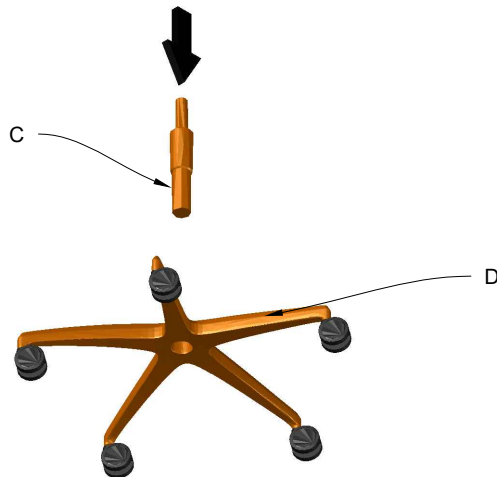

5) Colonna a gas (C) inserita nella base (D)
 5) Gas lift (C) inserted in the base (D)

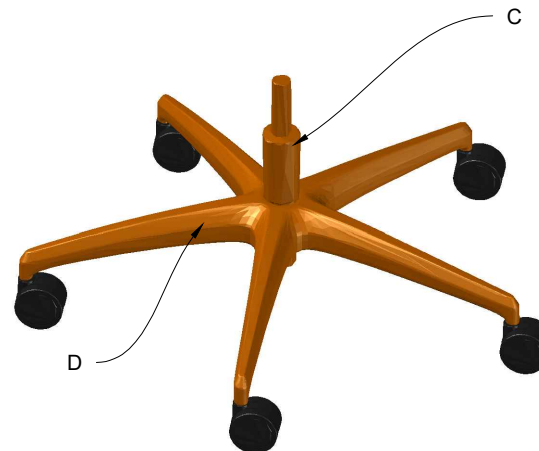

6) Fissare il movimento (E) al sedile (B) tramite i bulloni.
 6) Fasten the movement (E) to the seat (B) by means of the bolts

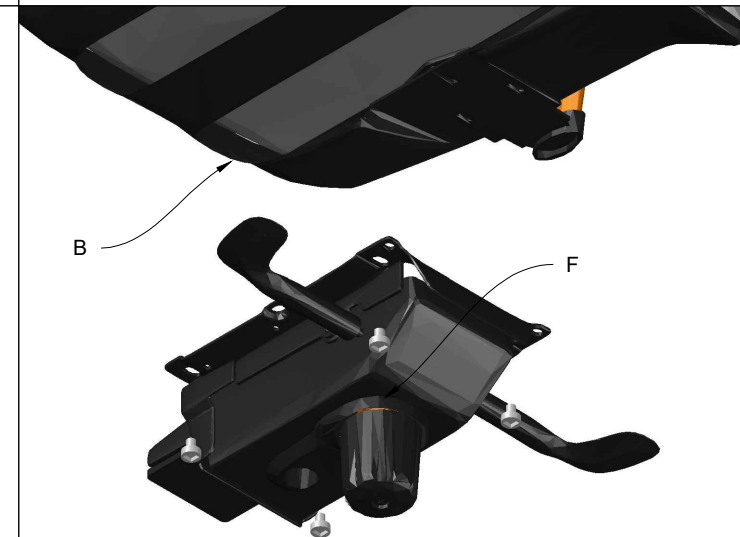

7) Inserire lo schienale (A) nel movimento (F) tramite i bulloni.

7) Insert the backrest (A) in the movement (F) by means of the bolts

8) Posizionare il cono del movimento (F) nella colonna a gas (C) in modo da unire la scocca e le parti assemblate precedentemente.

8) Position the cone of the movement (F) on the gas lift (C) to unite the body to the beforehand assembled parts

