





Ferramenta Hardware	Componenti Components										
Bullone 6x25 (T) 	Bolt 6x25 (T) n°4		Cassettiera (A) Chest of drawers (A)		Top (B) Top (B)						
Bullone 4x25 (U) 	Bolt 4x25 (U) n°6										
Ruota diam. 65 (V) 	Castor diam. 65 (V) n°4										
Maniglie (Z) 	Handles (Z) n°3										
Chiave esagonale 	Hexagonal key n°1										



Fig.1 agganciare le maniglie alla cassettera (A) tramite i bulloni (U)
Fig.1 Fasten the handles to the chest of drawers (A) by means of the bolts

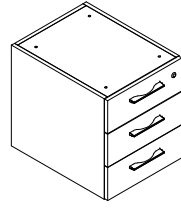
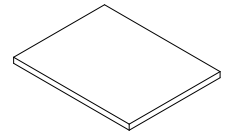

1) Ruotare la cassettera (A) in modo che si possano inserire le ruote (V) nella base negli appositi fori
1) Rotate the chest of drawers (A) in order to insert the castors (V) in the base in function to the designated holes

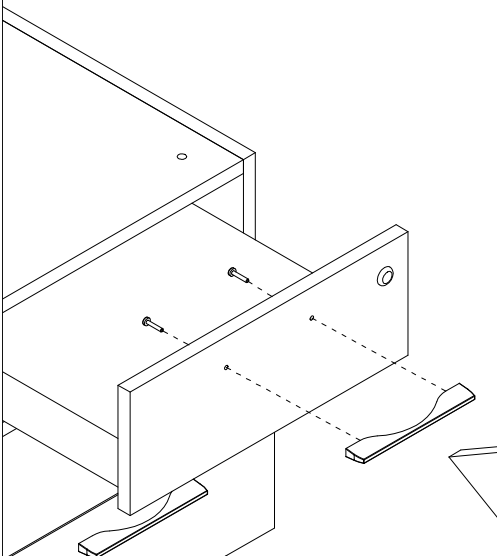
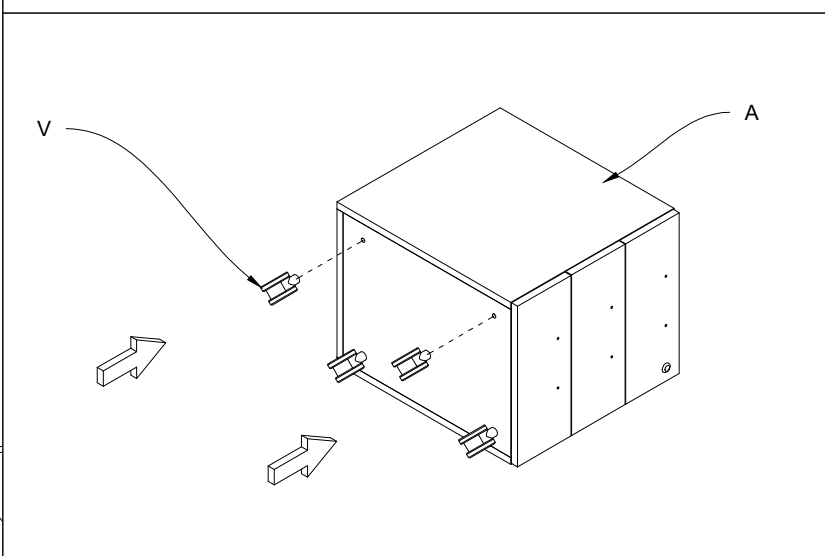

2) Inserire le maniglie (Z) nei frontali della cassettera tramite i bulloni (U)
2) Insert the handles (Z) in the fronts of the chest of drawers by means of the bolts (U)

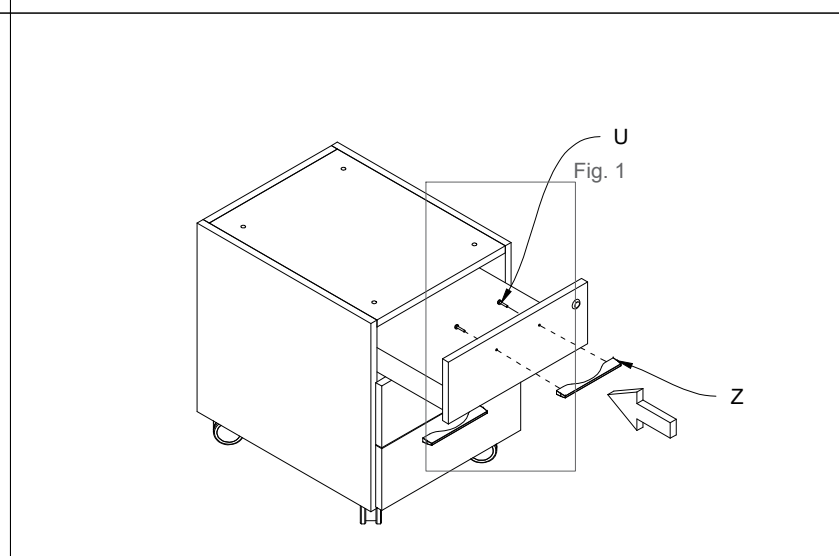

3) Inserire il top (B) sopra la cassettera attraverso i bulloni (T).
3) Place the top (B) above the chest of drawers by means of the bolts (T)

