







Ferramenta Hardware	Componenti Components							
Chiave esagonale Hexagonal key 	n°1	Piano (A) Top (A)		Gambone (B) Structural leg (B)		Piastra (C) Plate (C)		Base (D) Base (D)
Staffa (T) Bracket (T) 	n°4							
Bullone 6x16 (U) Bolt 6x16 (U) 	n°24							
Bullone 8x25 (V) Bolt 8x25 (V) 	n°8							
Bullone 8x25 (Z) Bolt 8x25 (Z) 	n°8							

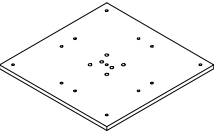
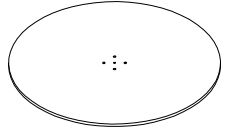
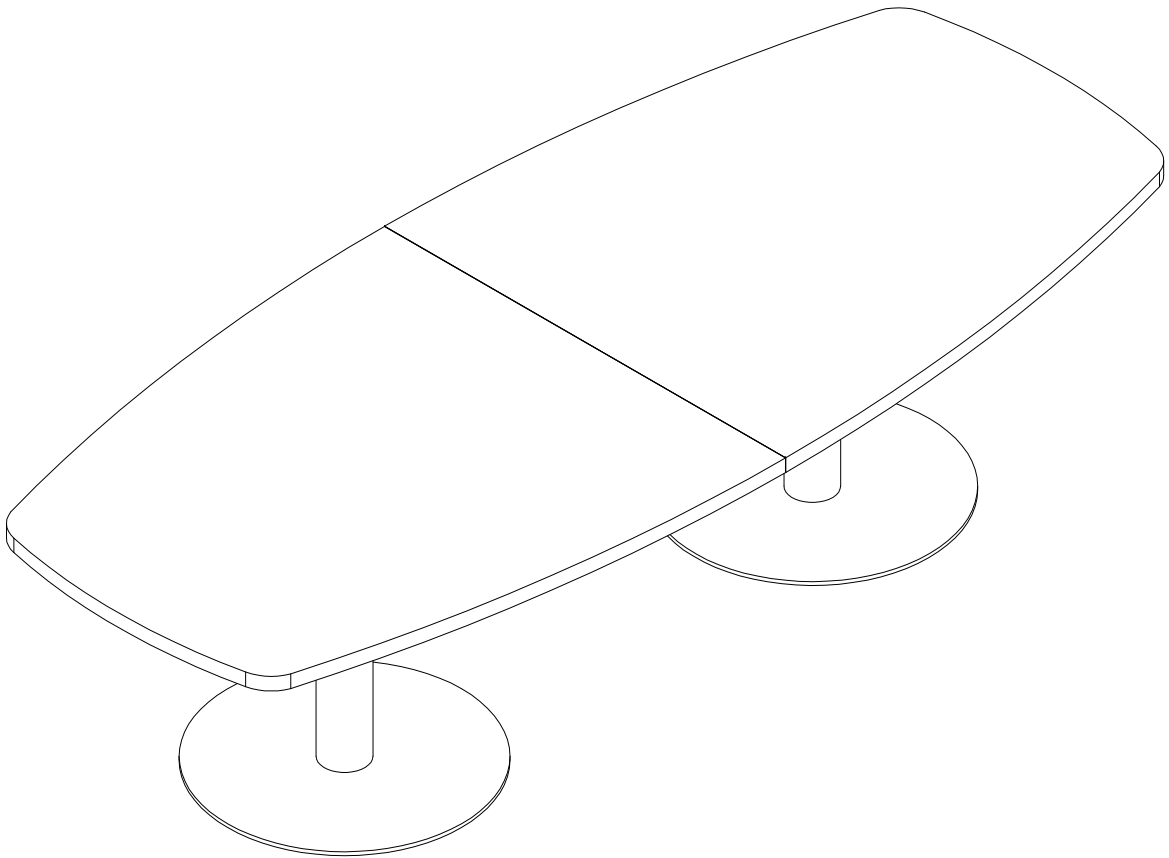
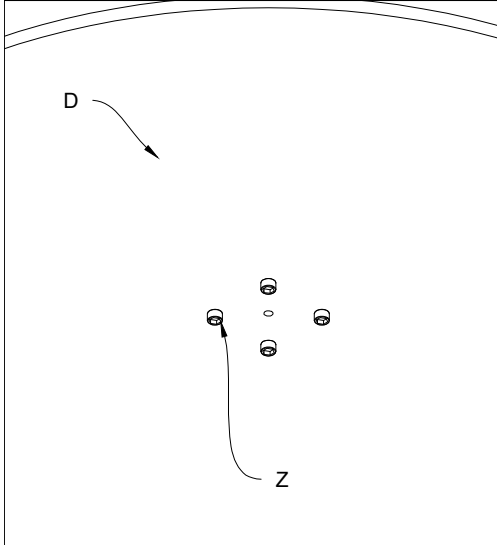

Fig.1 Fissare i bulloni (Z) nella base (D)

Fig.1 Fasten the bolts (Z) to the base (D)



1) Posizionare il gambone (B) sopra la base (D)

1) Position the structural leg (B) on top of the base (D)

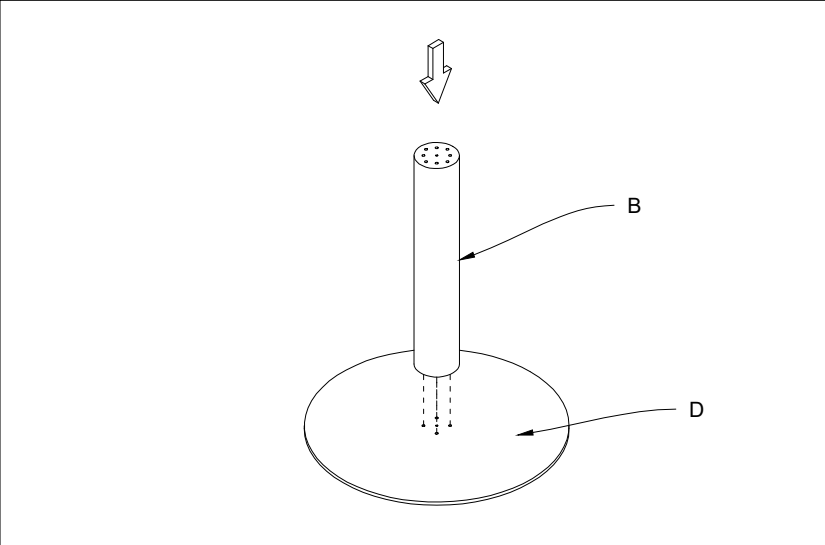

2) Unire il gambone (B) e la base (D) con i bulloni (Z)

2) Fasten the structural leg (B) to the base (D) by means of the bolts (Z)

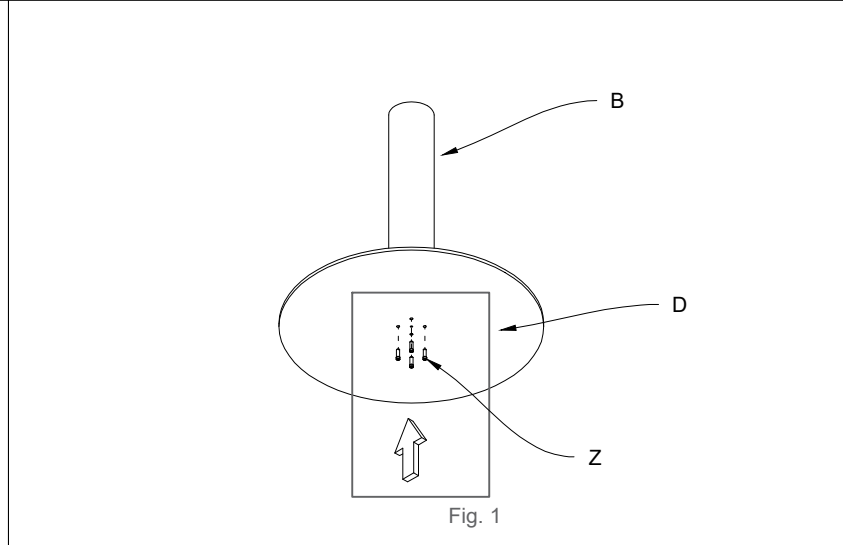
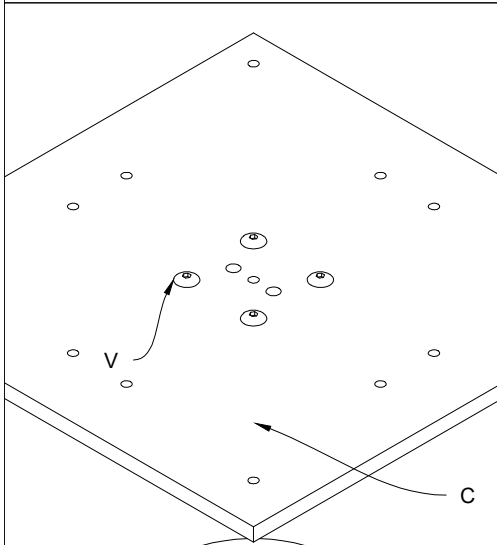
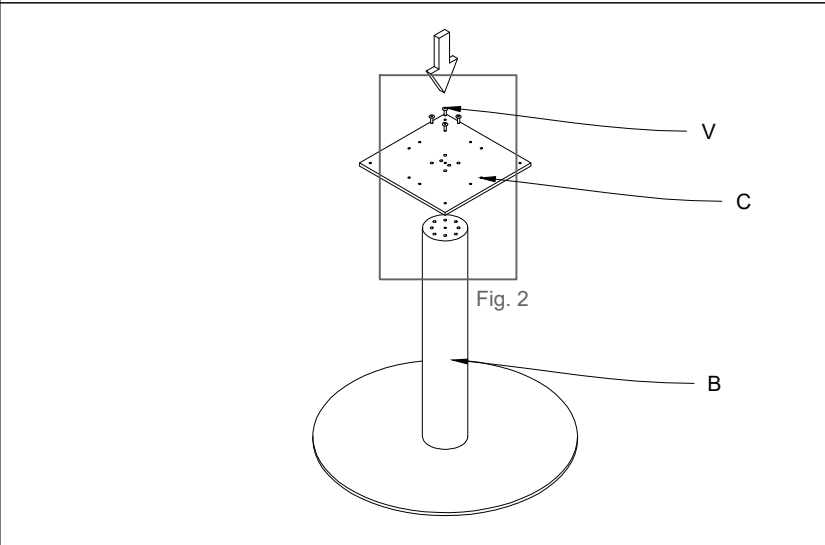

Fig.2 Fissare i bulloni (V) nella piastra (C)  
Fig.2 Insert the bolts (V) into the plate (C)



3) Posizionare la piastra (C) sopra il gambone (B) con i bulloni (V)  
3) Position the plate (C) on top of the structural leg (B) in function of the bolts (V)



4) Posizionare il gambone (B) sul piano (A).

4) Position the structural leg (B) on the top (A)

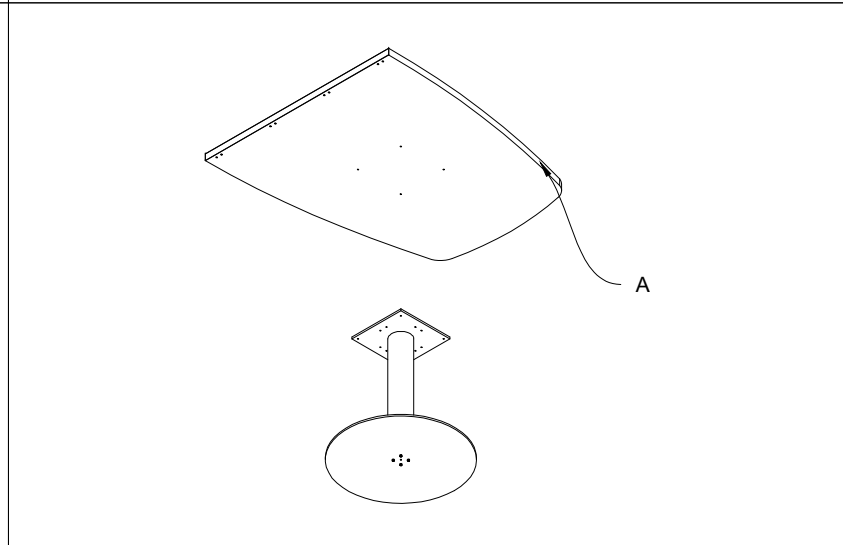
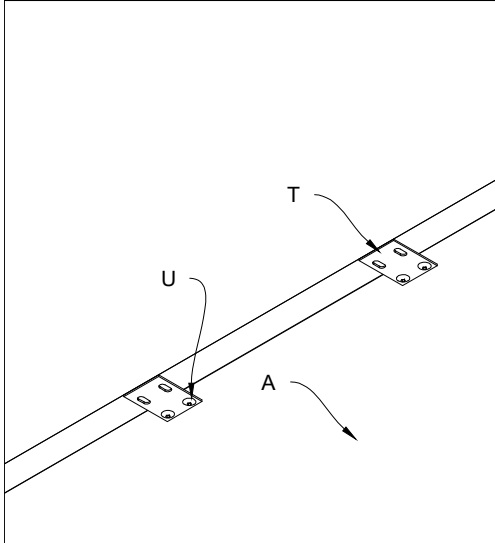
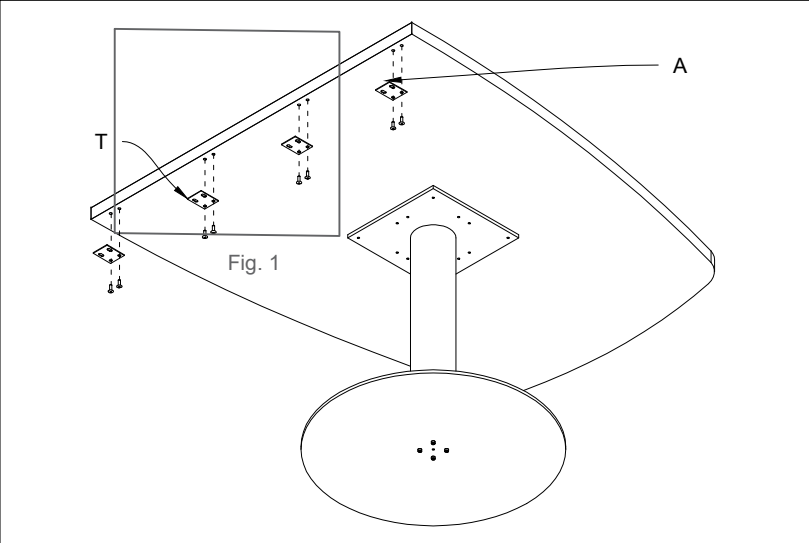

Fig.1 Fissare le staffe (T) tramite i bulloni(U) al piano (A)  
 Fig.1 Fasten the brackets (T) to the top (A) by means of the bolts (U)



5) Inserire le staffe (T) nel piano (A)  
 5) Insert the brackets (T) in the top (A)



6) Fissare il gambone (B) al piano (A) tramite i bulloni (U)  
 6) Fasten the structural leg (B) to the top (A) by means of the bolts (U)

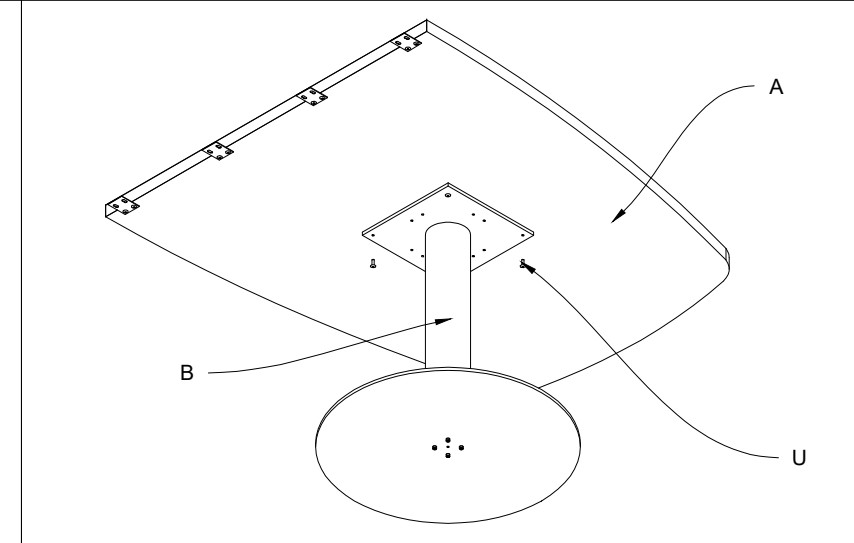
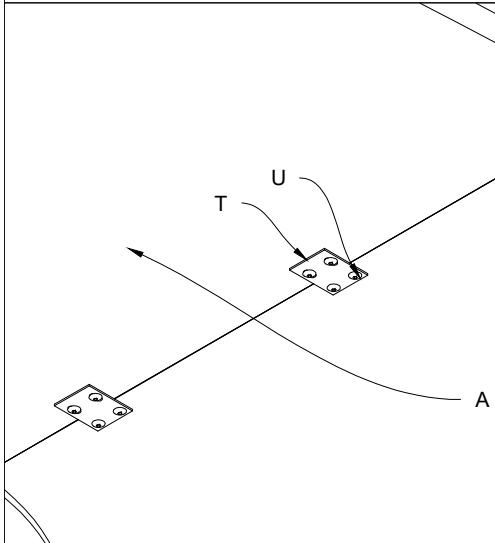

Fig.1 Fissare le staffe (T) tramite i bulloni(U) al piano (A)  
 Fig.1 Fasten the brackets (T) to the top (A) by means of the bolts (U)



6) Unire i due piani tramite le staffe (T) e i bulloni (U)  
 6) Unite the two tops by means of the brackets (T) and bolts (U)

