

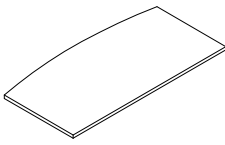

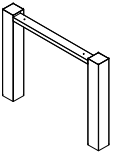

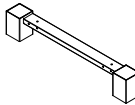







Ferramenta Hardware	Componenti Components									
Chiave esagonale (I) Hexagonal key (I)	n°1			Piano (A) Top (A)		Gamba DX-SX (B) R-L Leg (B)		Gamba DX-SX (C) R-L Leg (C)		Travi (D) Crossbars (D)
Bullone 6x60 (L) Bolt 6x60 (L)	n°4									
Distanziale (M) Spacer (M)	n°4									
Paracolpo (N) Strut (N)	n°4		Bullone 10x50 (V) Bolt 10x50 (V)	n°2						
Piedini diam. 35 (O) Feet diam. 35 (O)	n°2		Piastrina in plexiglass (Z) Plexiglass plate (Z)	n°2						
Rondella diam. 6 (P) Washer diam. 6 (P)	n°4									
Rondella diam. 10 (Q) Washer diam. 10 (Q)	n°2									
Dado 6 MA (R) Nut 6 MA (R)	n°4									
Bullone 6x16 (S) Bolt 6x16 (S)	n°4									
Bullone 6x20 (T) Bolt 6x20 (T)	n°24									
Bullone 6x45 (U) Bolt 6x45 (U)	n°4									

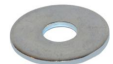
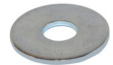
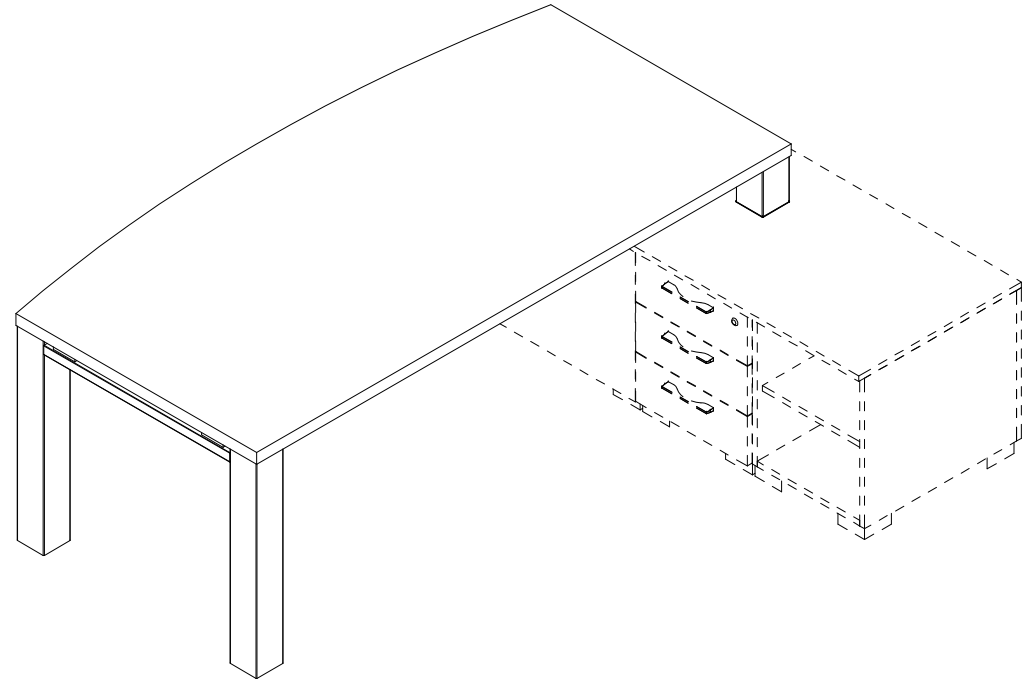

Fig.1 Posizionare i distanziali (M) tramite i bulloni (T)
Fig.1 Position the spacers (M) by means of the bolts (T)

1) Posizionare i distanziali (M) tramite i bulloni (T) e i piedini (O) sulla gamba (B).
1) Position the spacers (M) by means of the bolts (T) and feet (O) on the leg (B).

2) Posizionare i distanziali (M) tramite i bulloni (T) sulla gamba (B).
2) Position the spacers (M) by means of the bolts (T) on the leg (B).

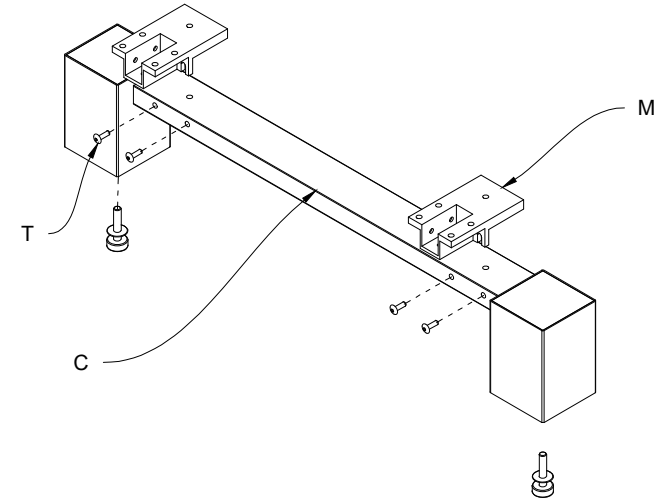
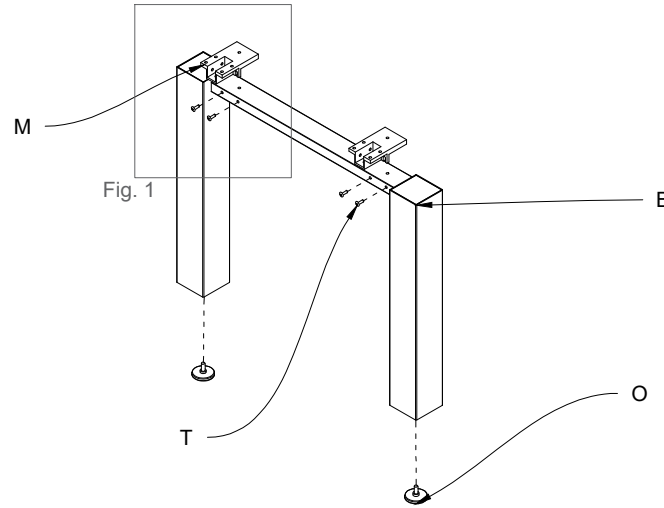
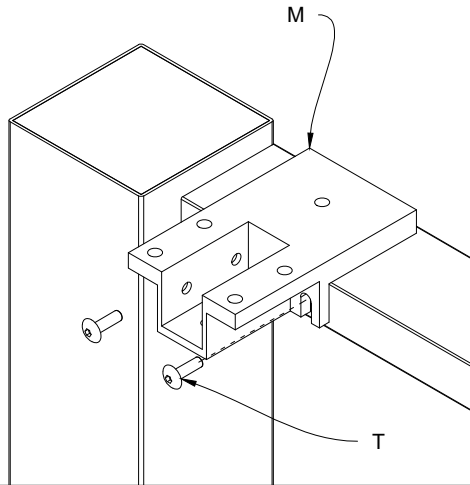

Fig.2 Inserire i bulloni (U) con la rondella (P) e il dado (R) e il bullone (S) tra la trave e il distanziale (M).
Fig.2 Insert the bolts (U), washer (P), nut (R) and bolt (S) between the crossbar and spacer (M).

3) Posizionare le travi (D) nei fianchi (B e C) e posizionare i paracolpi (N).
3) Position the crossbars (D) in the sides (B and C) and position the struts (N).

4) Posizionare le travi (D) nei distanziali delle gambe (B e C).
4) Position the crossbars (D) in the spacers of the legs (B and C).

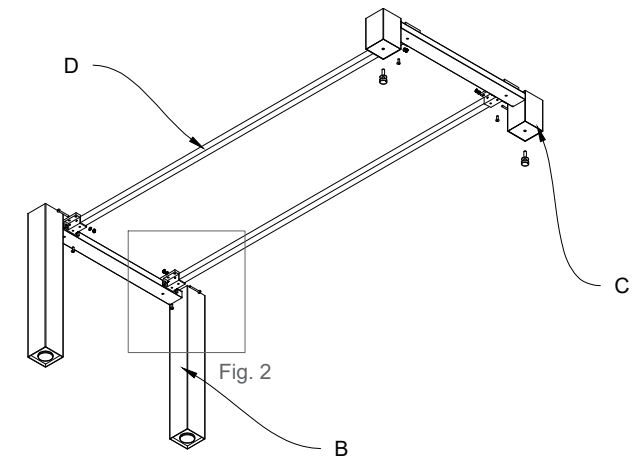
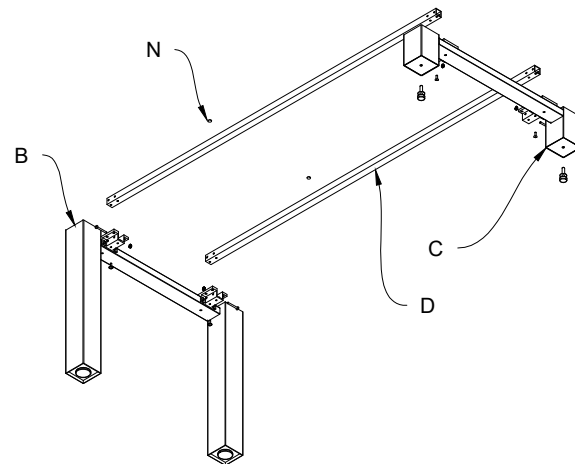
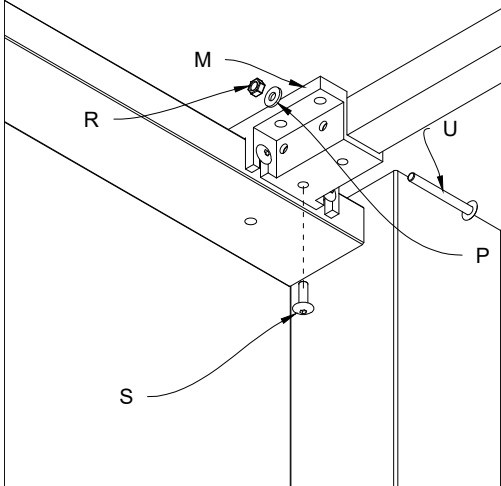
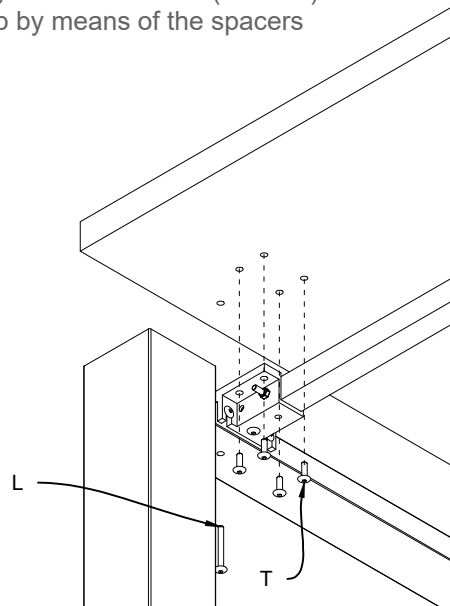
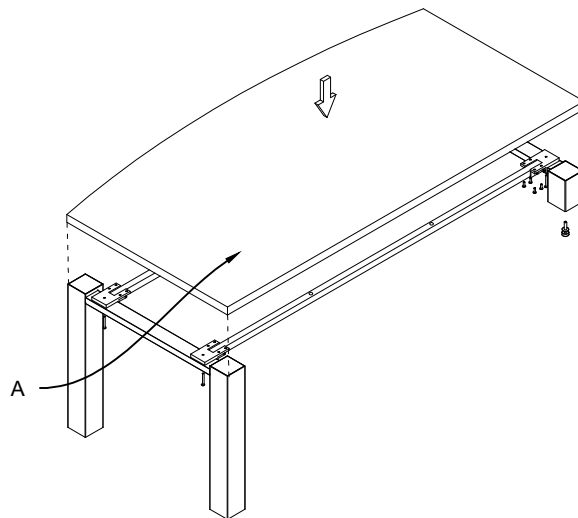

Fig.3 Inserire i bulloni (T e L) nel piano attraverso i distanziali
 Fig.3 Insert the bolts (T and L) in the top by means of the spacers



5) Posizionare il piano (A) sulla struttura in corrispondenza dei fori
 5) Position the top (A) on the structure in function of the holes



6) Inserire i bulloni nel piano (A) attraversando i distanziali (M)
 6) Insert the bolts in the top (A) by means of the spacers (M)

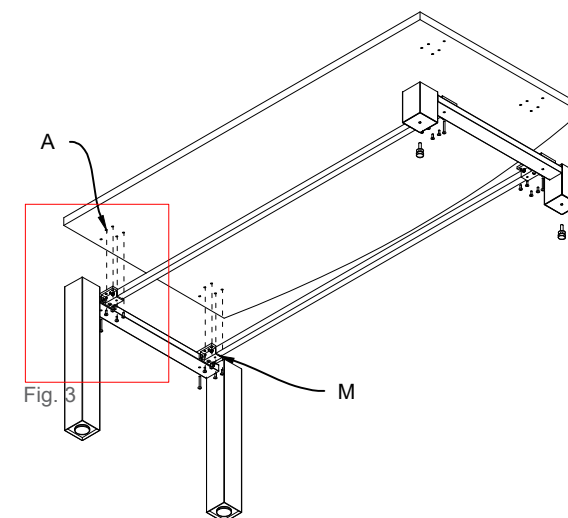
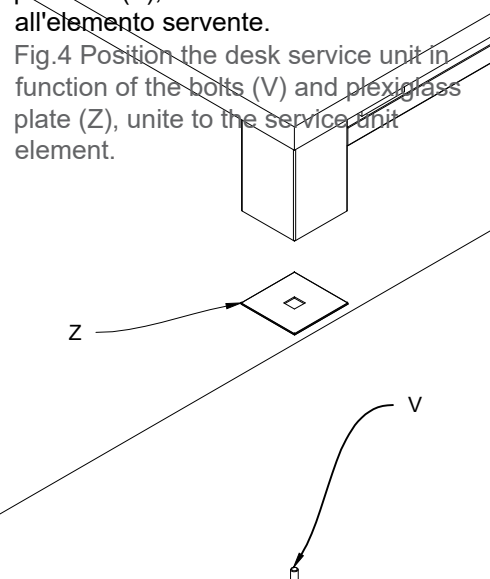
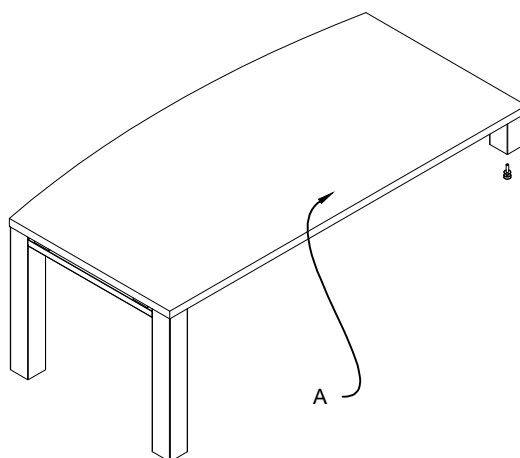

Fig.4 Posizionare la scrivania servente in corrispondenza dei bulloni (V) e della piastrina (Z), ed unire il tutto all'elemento servente.
 Fig.4 Position the desk service unit in function of the bolts (V) and plexiglass plate (Z), unite to the service unit element.



7) Unire il piano (A), alla struttura e serrare il tutto.
 7) Unite the top (A) to the structure and fasten



8) Unire la scrivania servente all'elemento servente tramite i bulloni (V), una rondella (Q) e la piastrina in plexiglass (Z).
 8) Unite the desk service unit to the service unit element by means of the bolts (V), washer (Q) and plexiglass plate (Z).

