

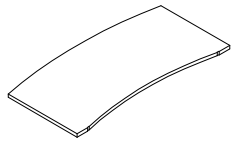

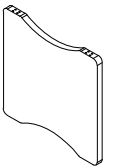

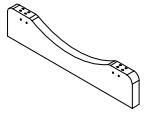





Ferramenta Hardware	Componenti Components		Piano (A) Top (A)		Fianco DX-SX (B) R-L Side (B)		Fianco DX-SX (C) R-L Side (C)		
Vite autofilettante 4x20 (N) 	Self-tapping screw 4x20 (N) <b>n°16</b>								
Spina in legno 8x30 (O) 	Wooden pin 8x30 (O) <b>n°12</b>								
Piedini regolabili diam.=35 (P) 	Adjustable feet diam.=35 (P) <b>n°2</b>								
Staffa a "L" (Q) 	"L" shaped bracket(Q) <b>n°4</b>								
Bullone 6x20 (R) 	Bolt 6x20(R) <b>n°16</b>								
Bullone 8x50 (S) 	Bolt 8x50 (S) <b>n°2</b>								
Grano 8x12 (T) 	Threaded screw 8x12 (T) <b>n°4</b>								
Barilotto 14x17 (U) 	Barrel 14x17 (U) <b>n°4</b>								
Tirante 7x33.5 (V) 	Tie-rod 7x33.5 (V) <b>n°4</b>								
Chiave esagonale 	Hexagonal key <b>n°1</b>								



**Fig.1 Posizionare barilotti (U) e grani (T) nel fianco (B).**  
 Fig.1 Position the barrels (U) and threaded screws (T) in the side (B).

**1) Posizionare i barilotti (U) e piedini (P) nel fianco (B).**  
 1) Position the barrels (U) and feet (P) in the side (B)

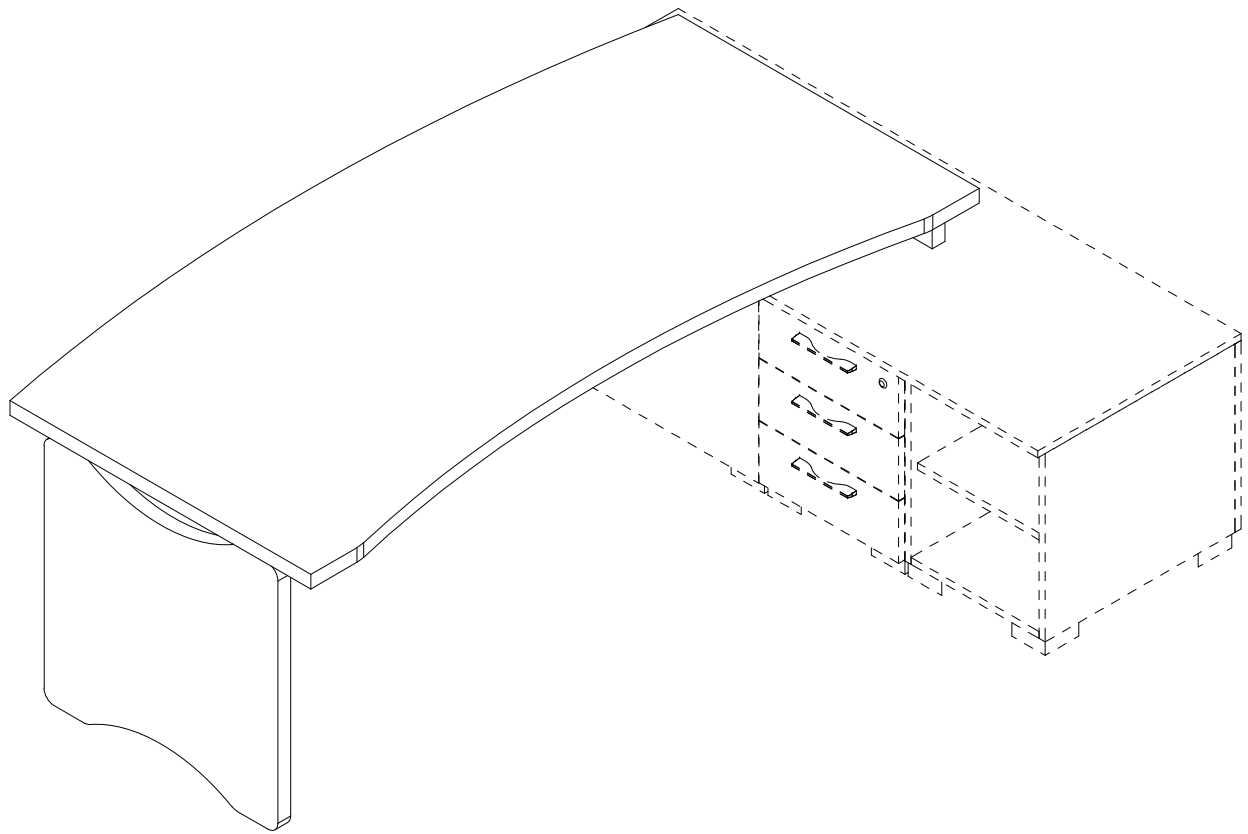
**2) Posizionare i barilotti (U) e grani (T) nel fianco (C).**  
 2) Position the barrels (U) and threaded screws (T) in the side (C)

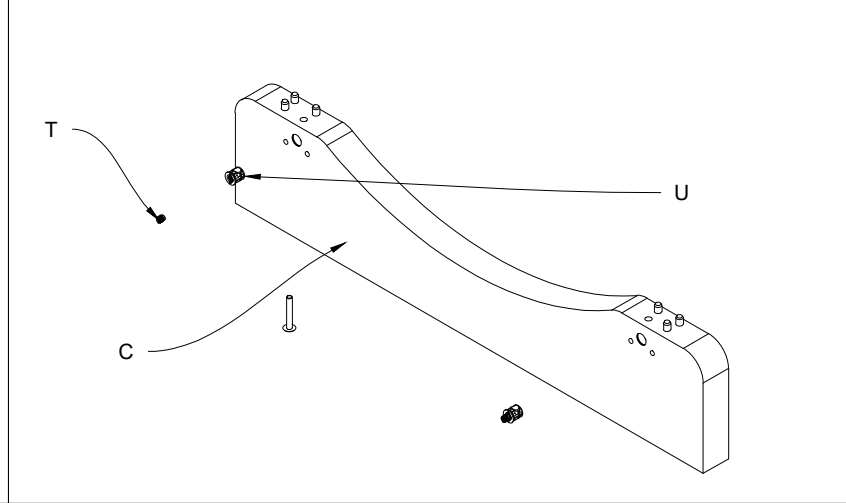
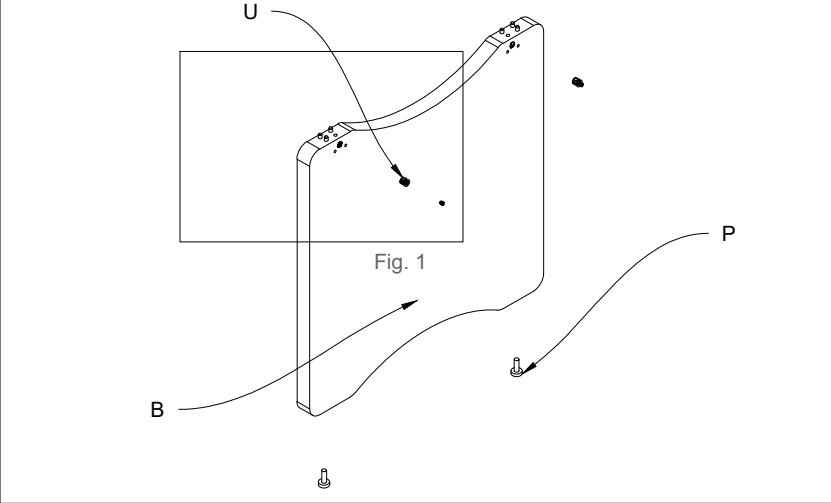
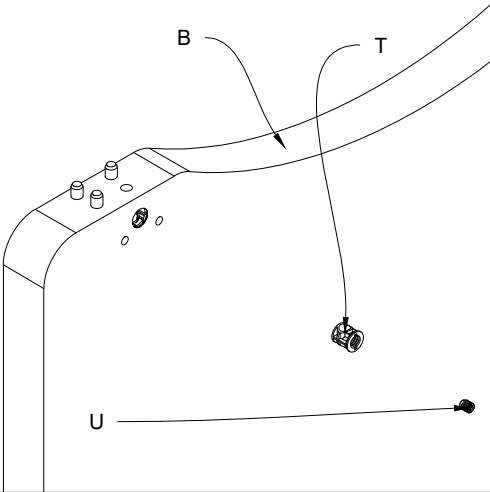

**Fig.2 Inserire i tiranti (V) nel piano (A) in corrispondenza dei fori.**  
 Fig.2 Insert the tie-rods (V) in the top (A) in function of the holes

**3) Posizionare i tiranti (V) nel piano (A).**  
 3) Position the tie-rods (V) in the top (A)

**4) Posizionare il piano (A) in corrispondenza dei fianchi (B e C) e serrare i grani**  
 4) Position the top (A) in function of the sides (B and C) and fasten threaded screws

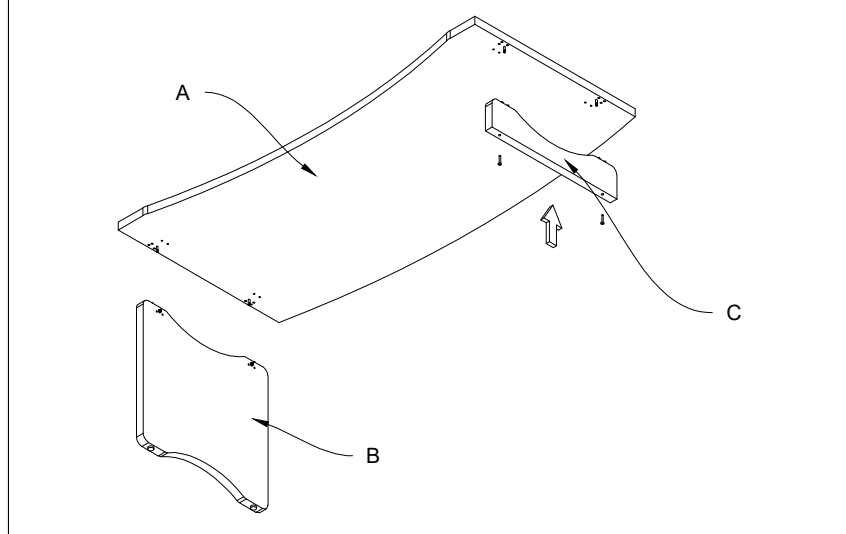
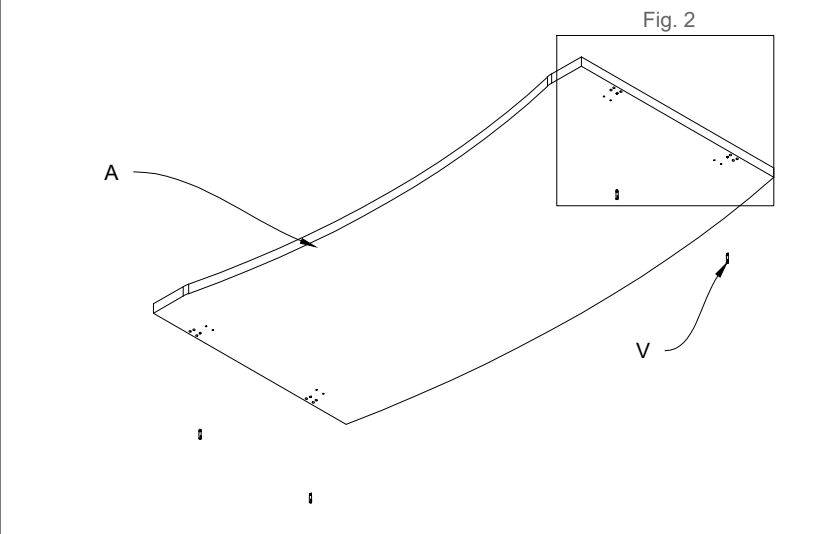
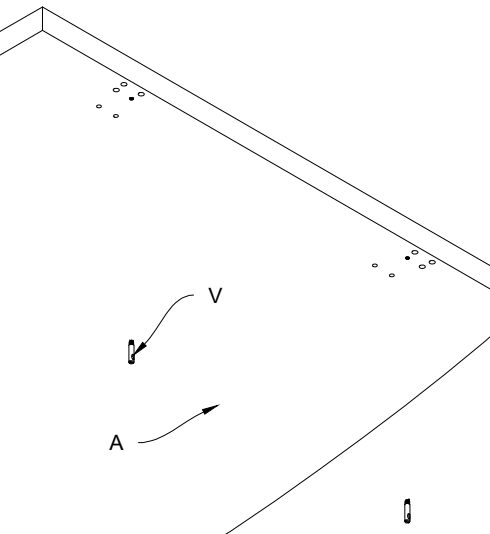
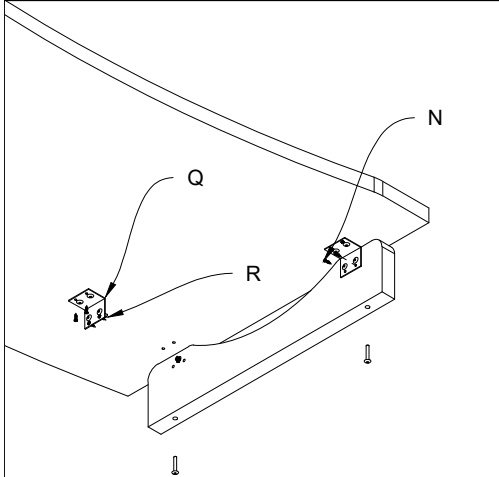
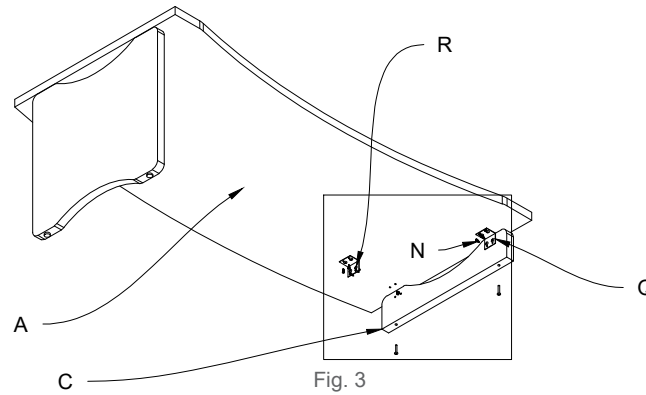

Fig.3 Posizionare le staffe (Q) con i bulloni(R) e le viti autofilettanti (N) in corrispondenza dei fori.  
 Fig.3 Position the brackets (Q) with the bolts (R) and self-tapping screws (N) in function to the holes



5) Serraggio grani.  
 6) Inserire il fianco (C) nel piano (A) tramite le staffe (Q) con i bulloni(R) e le viti auto filettanti (N).  
 5) Fasten threaded screws.  
 6) Insert the side (C) in the top (A) by means of the brackets (Q), bolts (R) and self-tapping screws (N).



6) Inserire il fianco (B) nel piano (A) tramite le staffe (Q) con i bulloni (R) e le viti auto filettanti (N).  
 6) Insert the side (B) in the top (A) by means of the brackets (Q), bolts (R) and self-tapping screws (N).

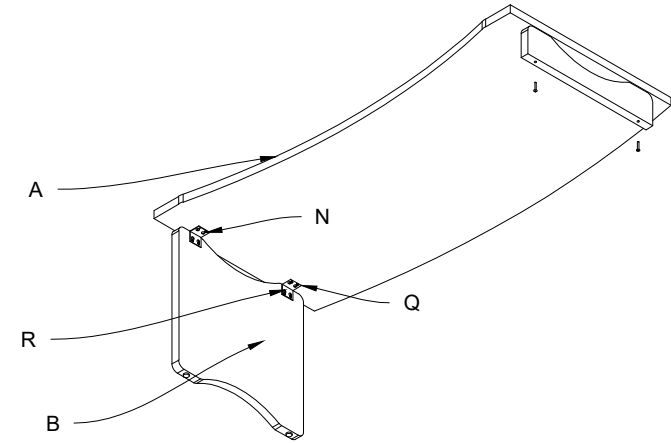
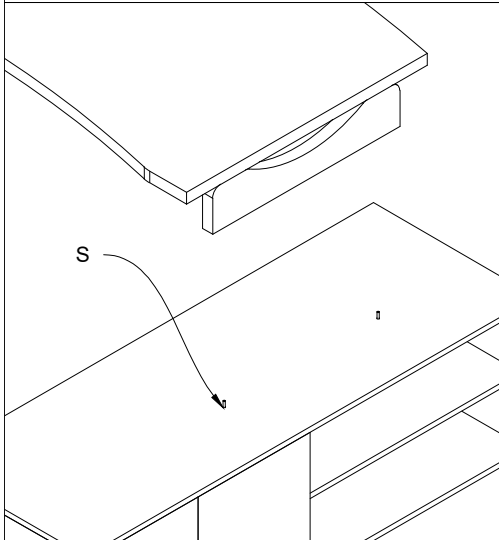

Fig.4 Posizionare la scrivania servente in corrispondenza dei bulloni (S) e unirla all'elemento servente.  
 Fig.4 Position the desk support unit in function to the bolts (S) and unite it to the service element unit



8) Unire la scrivania servente all'elemento servente tramite i bulloni (S).  
 8) Unite the desk support unit to the service element unit by means of the bolts (S)

