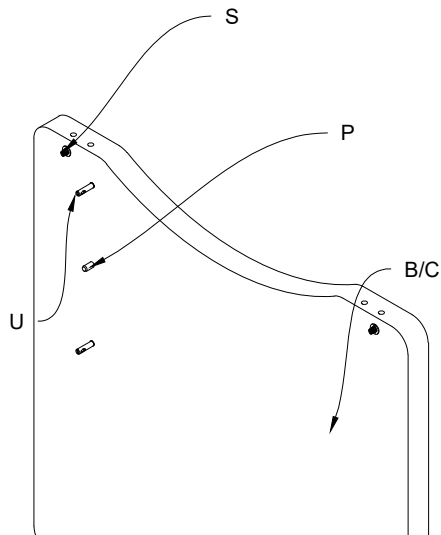
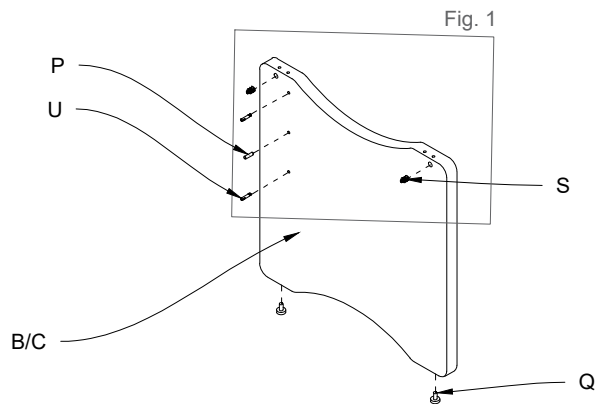



Fig.1 Posizionare spine (P), barilotti(S),tiranti(U) nei fianchi(B e C)  
 Fig.1 Position the pins (P), barrels (S) and tie-rods (U) in the sides (B and C)



1) Posizionare le spine (P), i barilotti (S), i tiranti (U) e piedini (Q) nei fianchi (B e C).  
 1) Position the pins (P), barrels (S), tie-rods (U) and feet (Q) in the sides (B and C)



2) Posizionare i barilotti (T) nella traversa (D).  
 2) Position the barrels (T) in the cross panel (D)

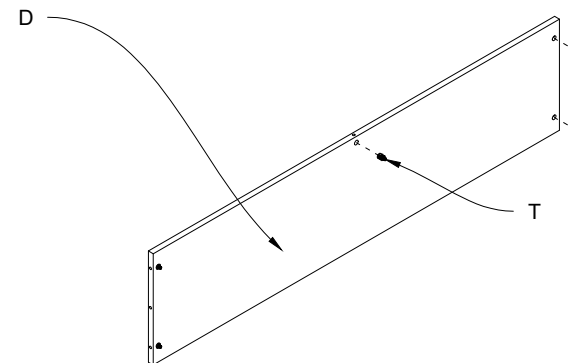
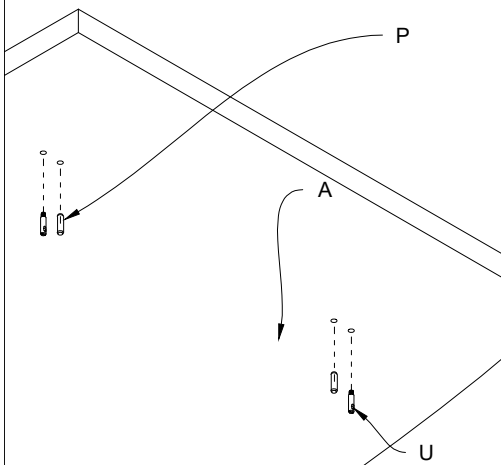
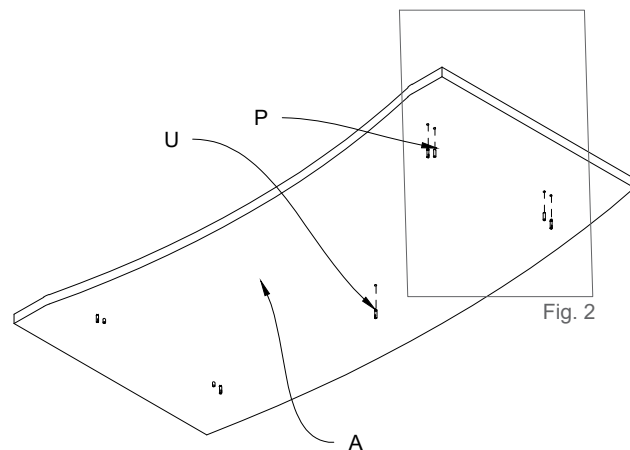

Fig.2 Posizionare spine (P) e tiranti(U) nel piano (A)  
 Fig.2 Position the pins (P) and tie-rods (U) in the top (A)



3) Posizionare le spine (P), e i tiranti(U) nel piano (A).  
 3) Position the pins (P) and tie-rods (U) in the top (A)



4) Unire i fianchi (B e C) alla traversa (D) tramite le spine (P) e i tiranti (U)  
 4) Unite the sides (B and C) to the cross panel (D) by means of the pins (P) and tie-rods(U)

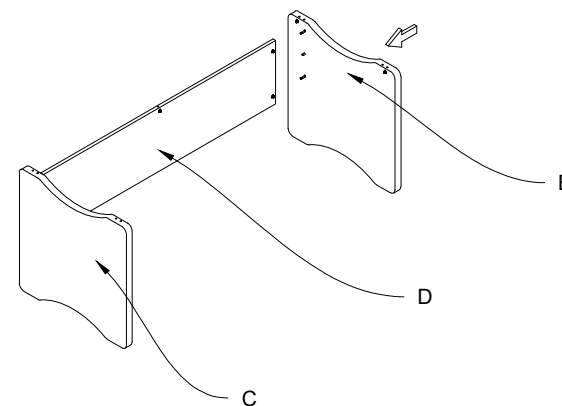

**Fig.1 Serraggio grani (V e R) nei barilotti (T e S)**  
**Fig.1 Tighten the treaded screws (V and R) in the barrels (T and S)**

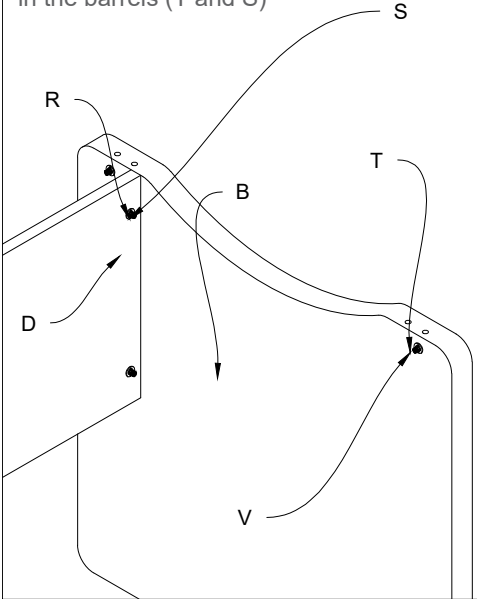

**5) Serraggio grani (V e R) nei barilotti(T e S)**  
**5) Tighten the treaded screws (V and R) in the barrels (T and S)**

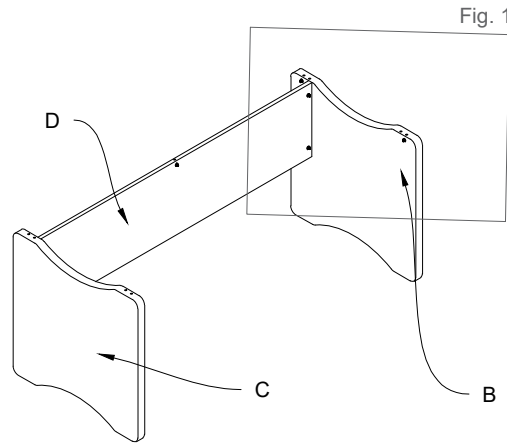

**6) Posizionare il Piano (A), sopra la struttura e agganciarlo tramite le spine (P) e i tiranti (U)**  
**6) Position the top (A) on top of structure and fasten it by means of the pins (P) and tie-rods (U)**

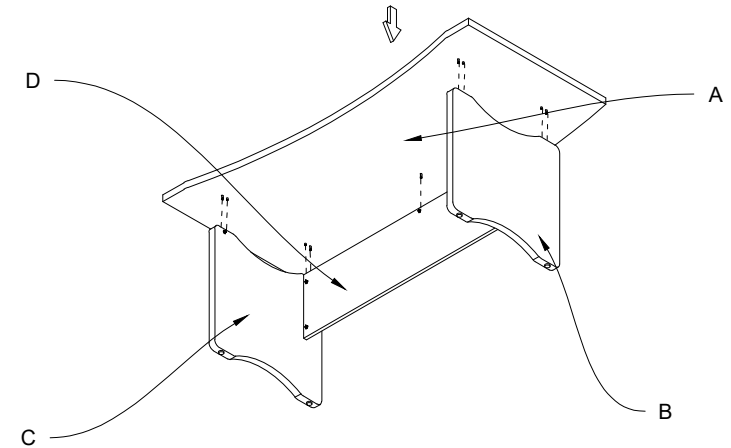

**Fig.2 Serraggio grani (V e R) nei barilotti (T e S)**  
**Fig.2 Tighten the treaded screws (V and R) in the barrels (T and S)**

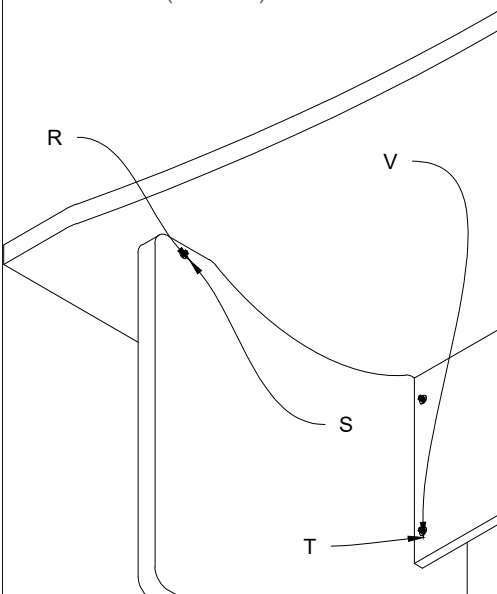

**7) Serraggio grani (V e R) nei barilotti(T e S)**  
**7) Tighten the treaded screws (V and R) in the barrels (T and S)**

