

Ferramenta Componenti
 Hardware Components

Cavo per pannelli BQ (S) Cable for pannels (S)



Morsetto (T) Clamp (T)



Grano (U) Threaded screw (U)



Tirante 7x33.5 (V) Tie-rod 7x33.5 (V)



Tassello (Z) Dowel (Z)

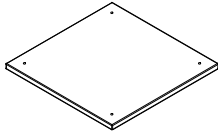

Pannello BQ
 (A)
 BQ panel (A)

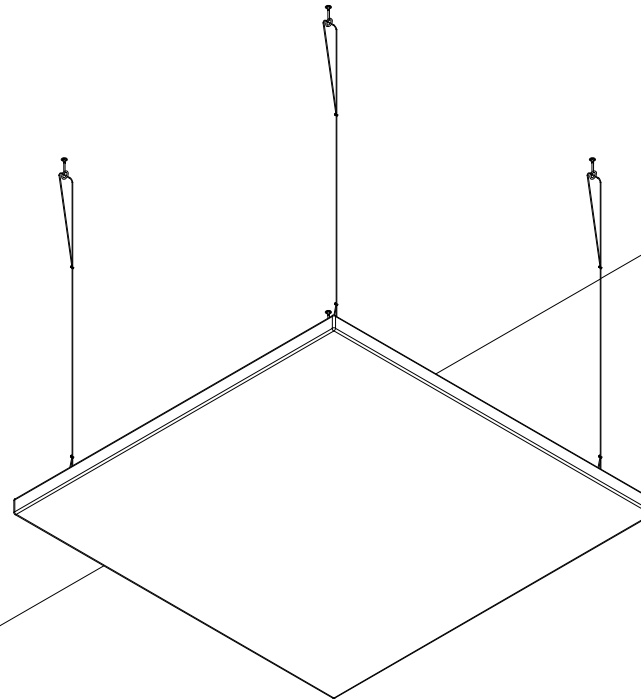

1) Inserire il cavo (S) all'interno dell'occhiello del tassello (Z).

1) Insert the cable (S) in the dowel (Z) loop

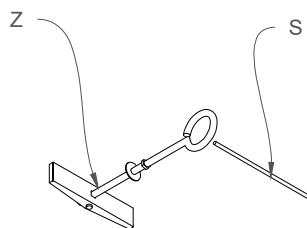

2) Dopo aver inserito il cavo (S) nel tassello, bloccare la fine del cavo con il morsetto (T) all'altezza desiderata e serrare il grano (U)

2) After inserting the cable (S) into the dowel (Z), block the end of the cable with the clamp (T) to the desired height and tighten the threaded screw (U)

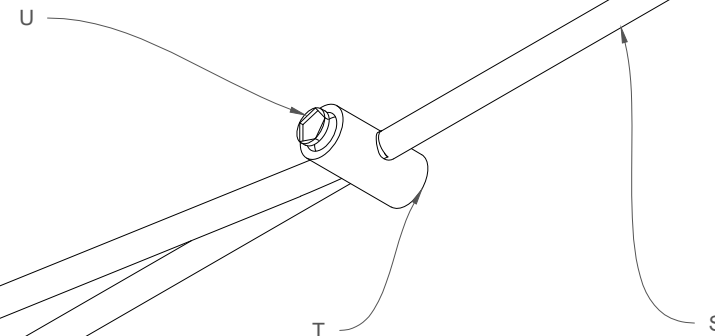

3) Forare il soffitto

3) Drill the ceiling

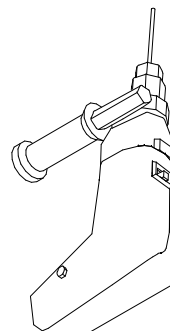

4) Inserire il tassello (Z) nel foro a soffitto

4) Insert the dowel (Z) in the ceiling hole

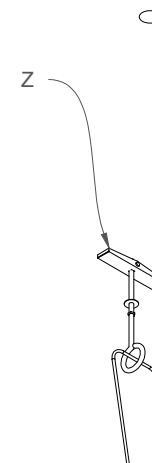

5) Inserire il tirante (V) all'interno del pannello (A) e avvitarlo nell'apposita predisposizione.

5) Insert the tie rod (V) inside the panel (A) and screw it into the appropriate predisposition.

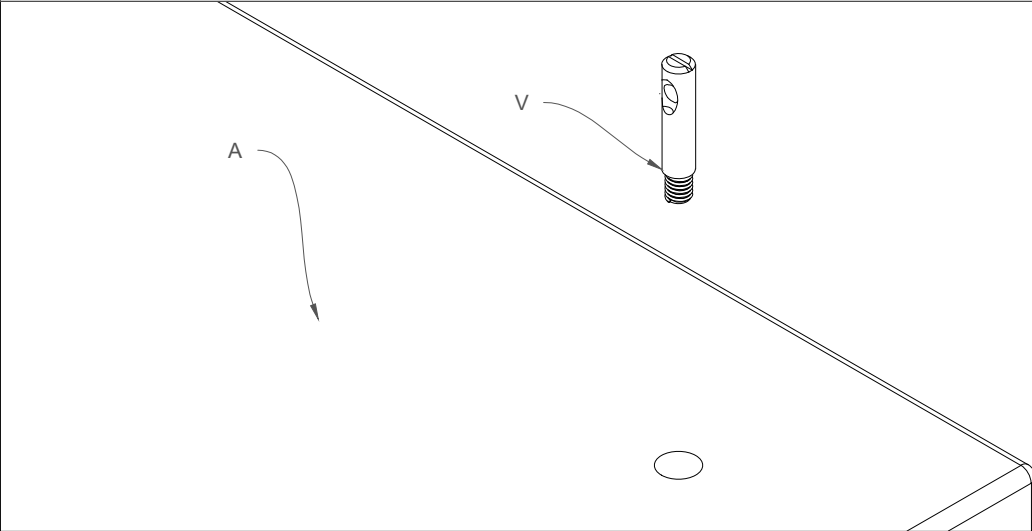

6) Inserire il cavo (S) all'interno dell'occhiello del tirante (V).

6) Insert the cable (S) inside the tie rod (V) loop.

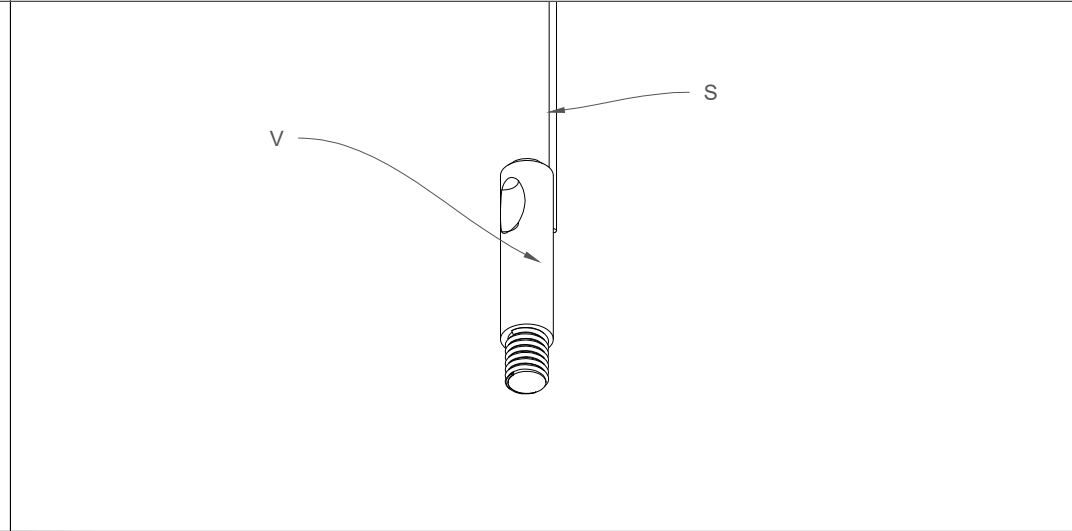

7) Dopo aver inserito il cavo (S) nel tirante, bloccare la fine del cavo con il morsetto (T) all'altezza desiderata e serrare il grano (U)

7) After inserting the cable (S) in the tie rod, block the end of the cable with the clamp (T) to the desired height and tighten the threaded screw (U)

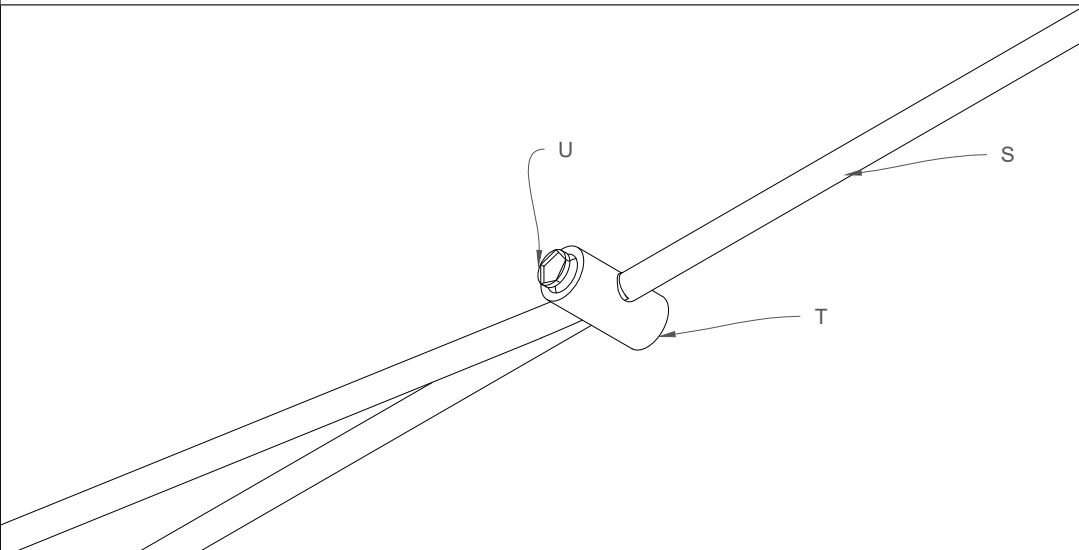

8) Ripetere tutti i passaggi per tutti i cavi

8) Repeat all steps for all cables

