











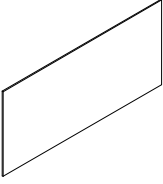
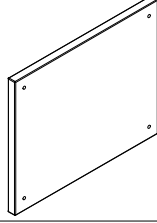
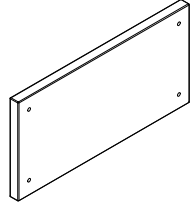



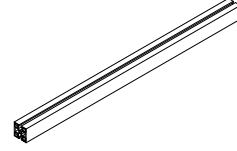

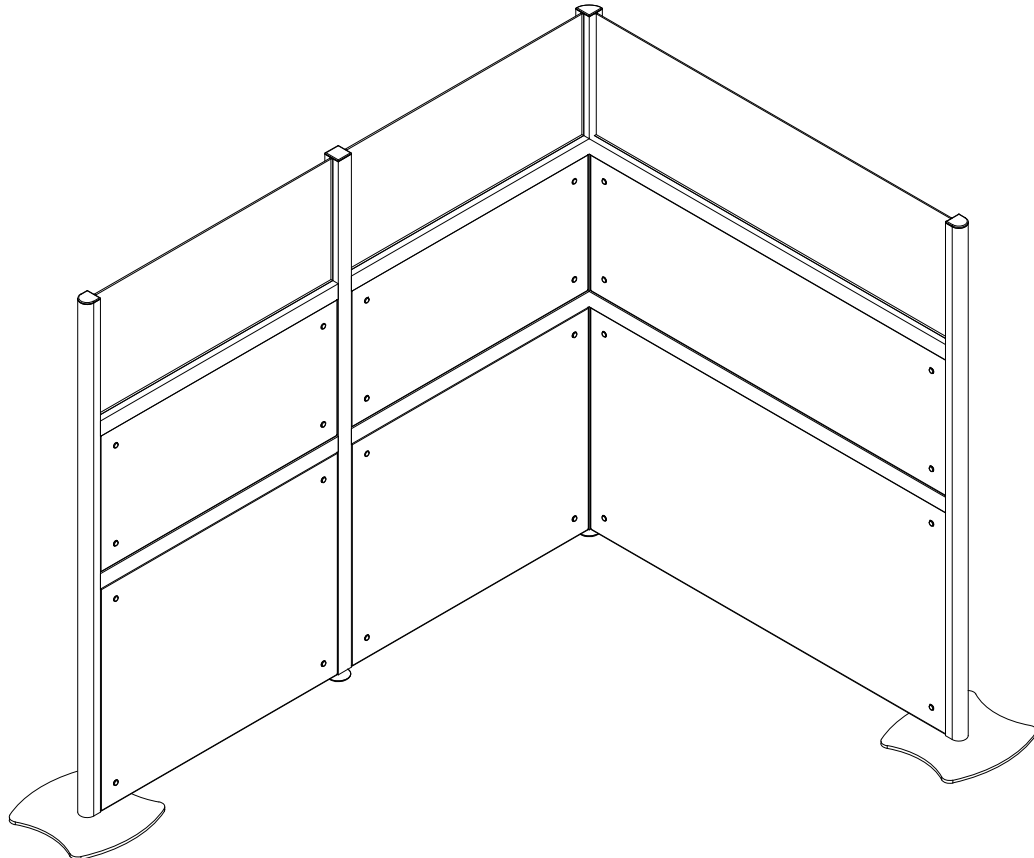
| Ferramenta Hardware | Componenti Components | | | | | | | | |
|--|--------------------------|---|---|--|--|---|---|---|---|
| Gomma per il metacrilato (L)  | n°3 |  | Pannello in metacrilato (A) Methacrylate panel (A) |  | Pannello inferiore (B) Lower panel (B) |  | Pannello superiore (C) Upper panel (C) |  | Montante stondato 1 via (D) Rounded one-way column (D) |
| Rondella (M)  | n°2 |  | Montante 2 vie (E) Two-way column (E) |  | Traversa 2 vie (F) Two-way crossbar (F) |  | Montante stondato 2 vie (G) Rounded two-way column (G) | | |
| Piedino (N)  | n°2 |  | | | | | | | |
| Tappi copri barilotti (O)  | n°24 | | | | | | | | |
| Tirante 10x46 (P)  | n°24 | | | | | | | | |
| Barilotto 14x17.5 (Q)  | n°24 | | | | | | | | |
| Grano 8x12 (R)  | n°24 | | | | | | | | |
| Dado a molla (S)  | n°24 | | | | | | | | |
| Plastrine per traverse (T)  | n°12 | | | | | | | | |
| Piede autoportante (U)  | n°2 | | | | | | | | |
| Bullone 10x20 (V)  | n°2 | | | | | | | | |
| Tappi per i montanti (Z)  | n°4 | | | | | | | | |

Fig.1 Inserimento del piedino (N) con la rondella (M) e del piedino autoportante (U) con il bullone (V).
Fig.1 Insert the foot (N) by means of the washer (M), insert the self bearing foot (U) by means of the bolt (V)

1) Inserire il piedino (N) con la rondella (M) e il piedino autoportante (U) con il bullone (V) nei montanti a 2 e 1 via (D, G e E).
1) Insert the foot (N) by means of the washer (M), insert the self bearing foot (U) by means of the bolt (V) in the two and one-way columns (D, G and E)

2) Inserire i barilotti (Q) e i tiranti (P) con il dado a molla (S) nei pannelli fonoassorbenti superiori (B e C).
2) Insert the barrels (Q) and the tie-rods (P) by means of the spring nut (S) in the upper sound absorbing panels (B and C)

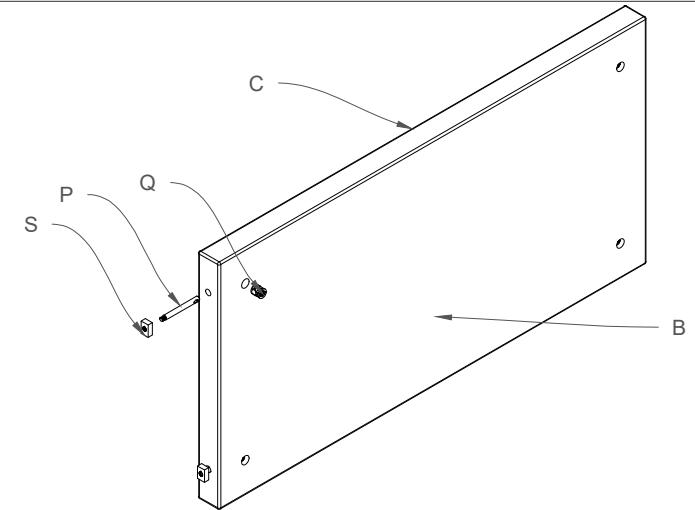
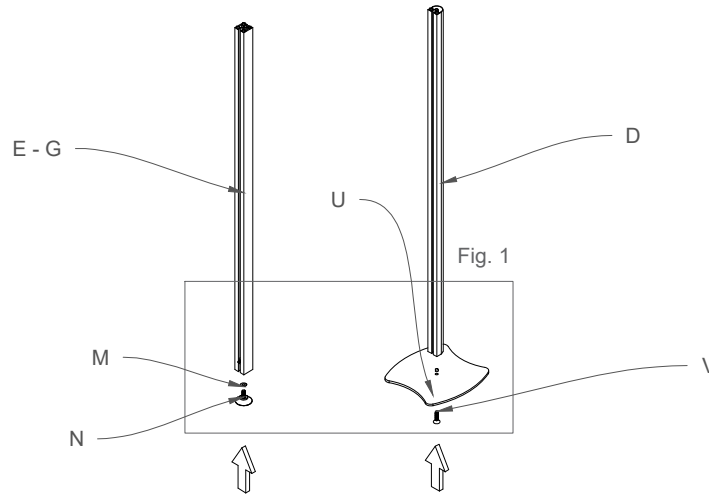
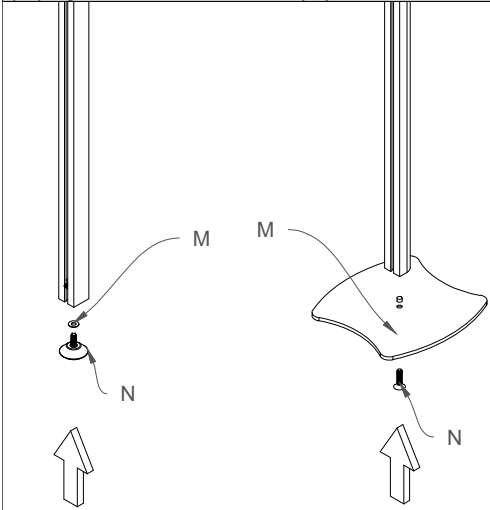

Fig.2 Serraggio del grano (R) nei barilotti (Q).
Fig.2 Tighten the threaded screws (R) in the barrels (Q)

3) Inserire i fianchi e i frontali fonoassorbenti inferiori (B) nei montanti (D, G e E) tramite i tiranti (P) con i dadi a molla (S).
3) Insert the sides and lower frontal sound absorbing panels (B) in the columns (D, G and E) by means of the tie-rods (P) and spring nuts (S)

4) Inserire le traverse a 2 vie (F) nei montanti (D, G e E).
4) Insert the two-way crossbars (F) in the columns (D, G and E)

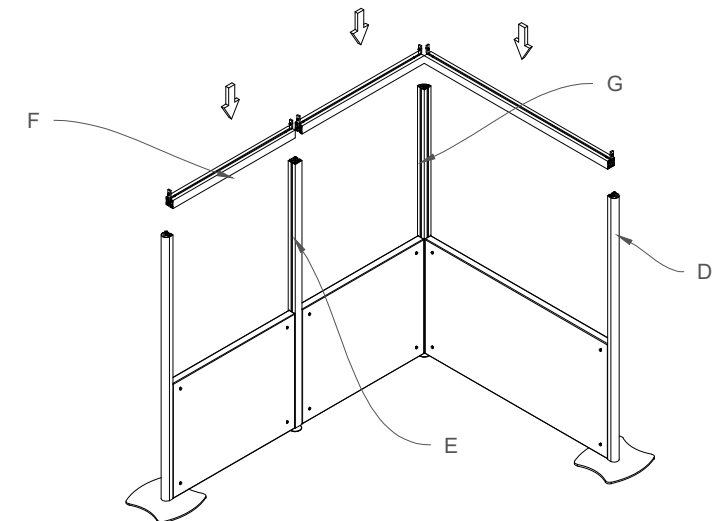
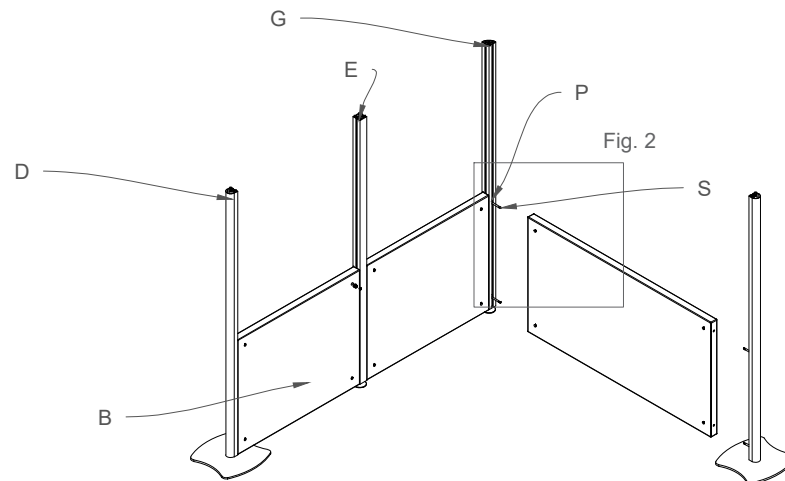
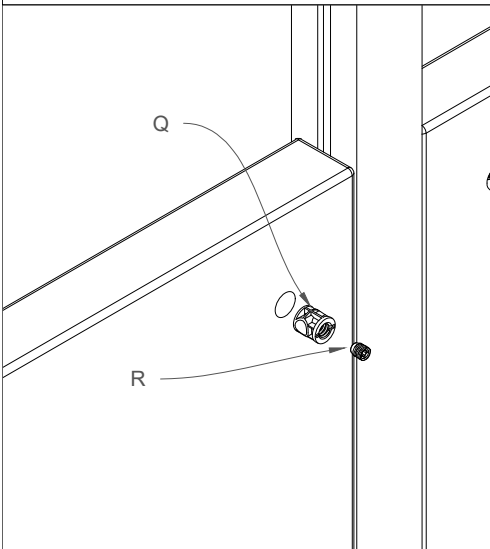
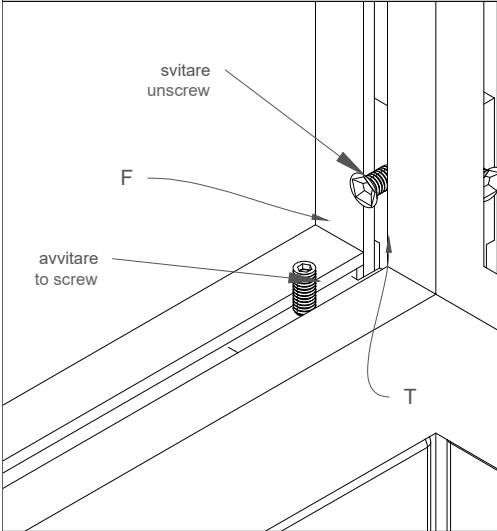
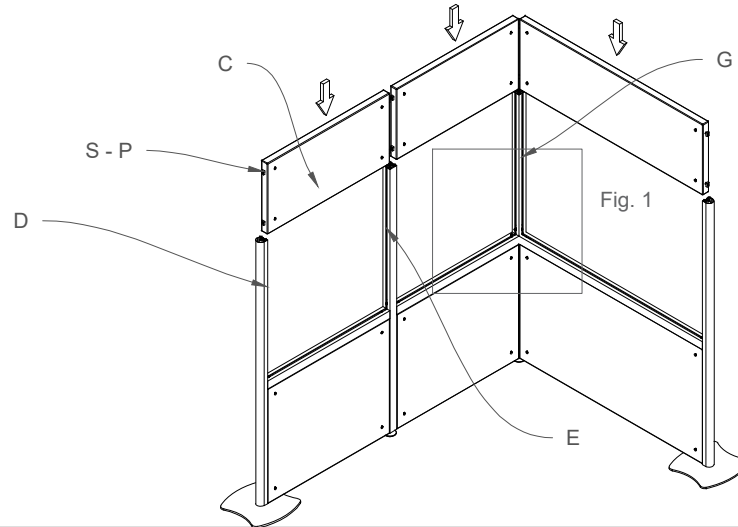

Fig.1 Serraggio delle traverse (F) nei montanti (D) con le piastrine (T).
 Fig.1 Tighten the crossbars (F) in the columns (D) with plates (T).



5) Inserire i pannelli superiori (C) nei montanti (D, G e E) tramite i tiranti (P) con i dadi a molla (S)
 5) Insert the upper panels (C) in the columns (D, G and E) by means of the tie-rods (P) and spring nuts (S)



6) Inserire le traverse a 2 vie (F) nei montanti (D, G e E)
 6) Insert the two-way crossbars (F) in the columns (D, G and E)

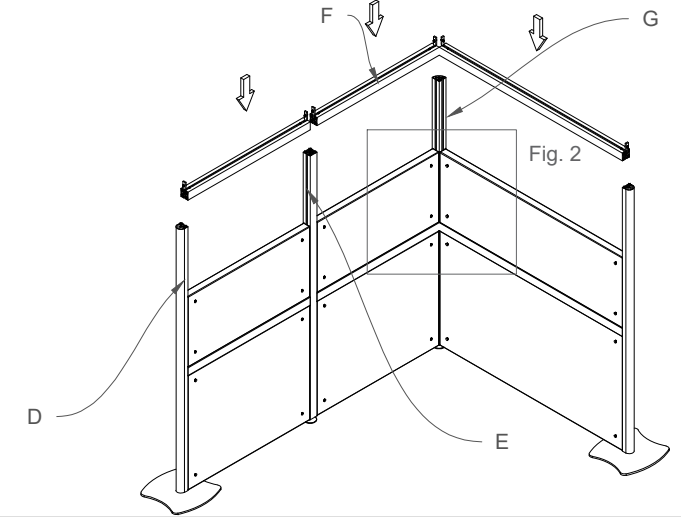
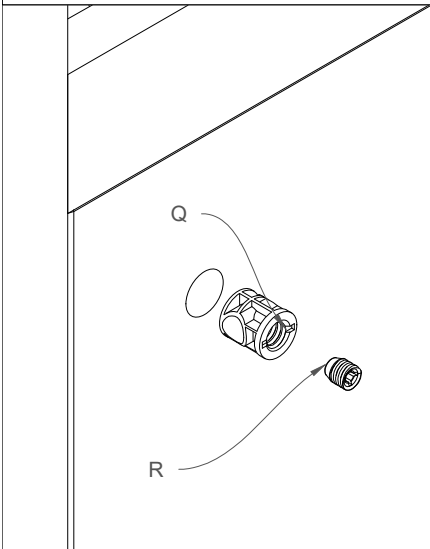
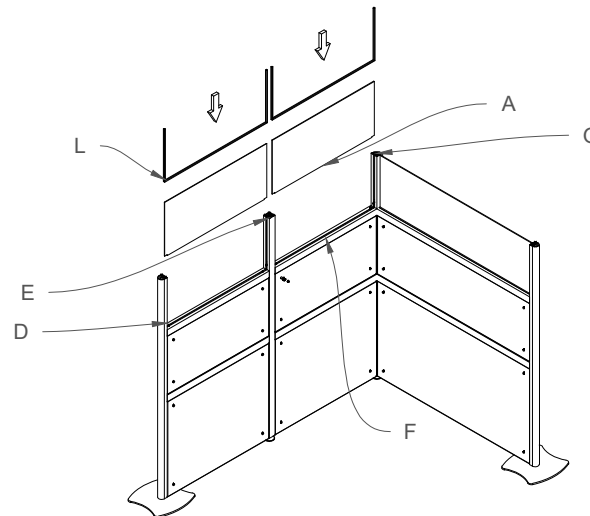

Fig.2 Serraggio del grano (R) nei barilotti (Q).
 Fig.2 Tighten the threaded screws (R) in the barrels (Q)



7) Inserire il pannello in metacrilato (A) nella traversa (F) e nei montanti (D, G e E) e fissarlo tramite la gomma (L)
 7) Insert the methacrylate panel (A) in the crossbar (F) and in the columns (D, G and E), fasten it by means of the rubber (L)



8) Inserire i tappi per i montanti (Z) e i copri barilotti (O)
 8) Insert the column (Z) and barrel (O) caps

