











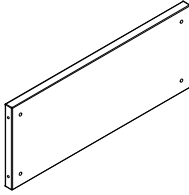
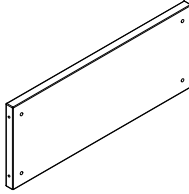
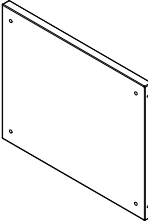



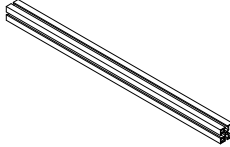

Ferramenta Hardware	Componenti Components								
Gomma per il metacrilato (L) Rubber for the methacrylate (L)	n°2		Piano da lavoro (A) Worktop (A)		Pannello laterale superiore (B) Upper lateral panel (B)		Pannello frontale superiore (C) Upper front panel (C)		Pannello laterale inferiore (D) Lower lateral panel (D)
Rondella (M) Washer (M)	n°9		Pannello frontale inferiore (E) Lower front panel (E)		Montante stonato 1 via (F) Rounded one-way column (F)		Montante 3 vie (G) Three-way column (G)		Traversa 3 vie (H) Three-way crossbar (H)
Piedino (N) Foot (N)	n°9								
Tappi copri barilotti (O) Barrel caps (O)									
Tirante 10x46 (P) Tie-rod 10x46 (P)	n°88								Pannello in metacrilato (I) Methacrylate panel (I)
Barilotto 14x17.5 (Q) Barrel 14x17.5 (Q)	n°88								Traversa a 2 vie (J) Two-way crossbar (J)
Grano 8x12 (R) Threaded screw 8x12 (R)	n°88								Montante 4 vie (K) Four-way column (K)
Dado a molla (S) Spring nut (S)	n°88								
Piastrine per traverse (T) Plates for crossbars (T)	n°88								
Piastrine per piano (U) Plates for tops (U)	n°12								
Viti 4x30 (V) Screws 4x30 (V)	n°16								
Tappi per i montanti (Z) Caps for columns (Z)	n°32								
	n°9								

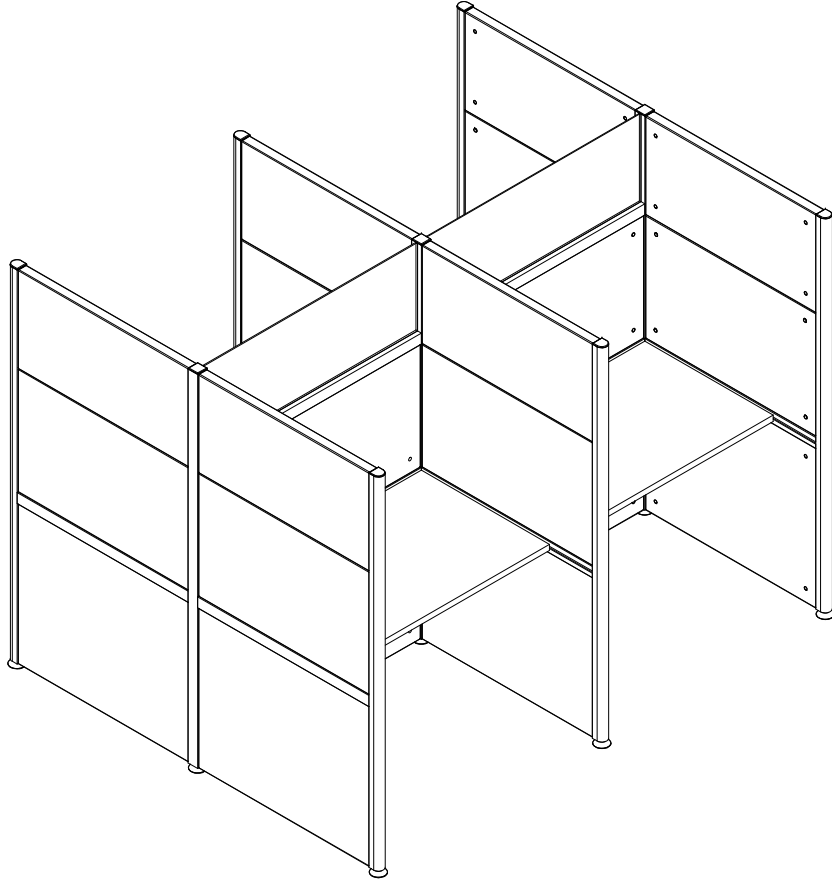
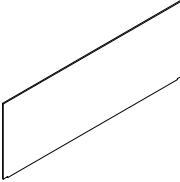
Fig.1 Inserimento del piedino (N) con la rondella (M).  
Fig.1 Insert the foot (N) by means of the washer (M)

1) Inserire il piedino (N) con la rondella (M) nei montanti a 3, 4 e 1 via (G, K e F).

1) Insert the foot (N) by means of the washer (M) in the one, four or three-way columns (F, K and G)

2) Inserire i barilotti (Q) e i tiranti (P) con il dado a molla (S) nei pannelli fonoassorbenti superiori (B e C).

2) Insert the barrels (Q) and the tie-rods (P) by means of the spring nut (S) in the upper sound absorbing panels (B and C)

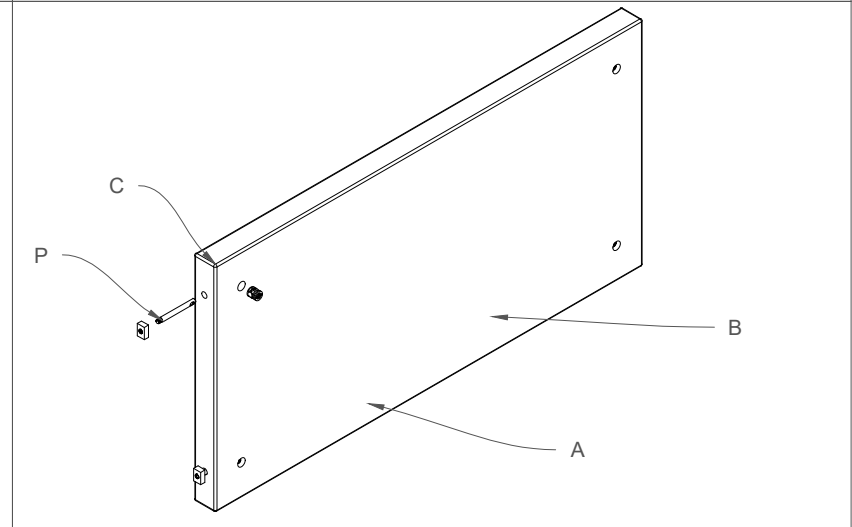
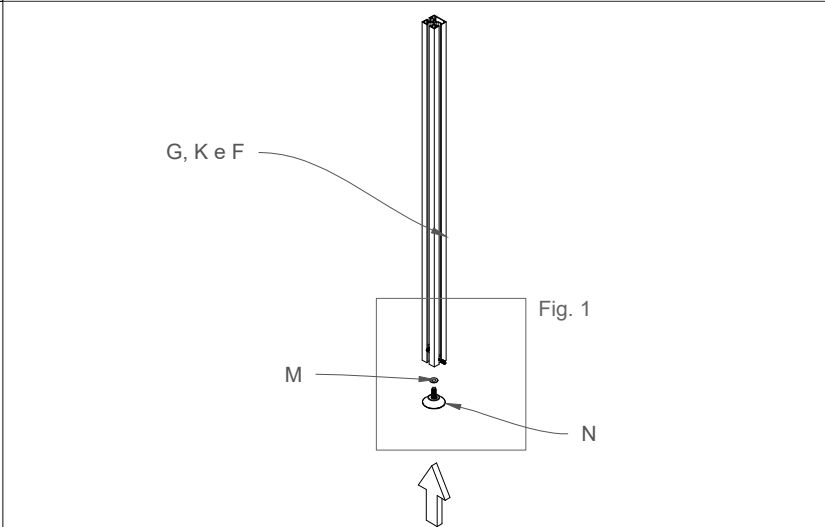
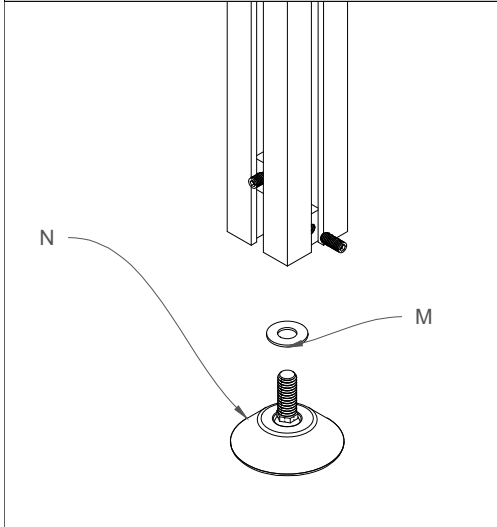

Fig.2 Serraggio del grano (R) nei barilotti (Q).  
Fig.2 Tighten the threaded screws (R) in the barrels (Q)

3) Inserire i fianchi e i frontali fonoassorbenti inferiori (D e E) nei montanti (F, K e G) tramite i tiranti (P) con i dadi a molla (S).  
3) Insert the sides and lower frontal sound absorbing panels (D and E) in the columns (F, K and G) by means of the tie-rods (P) and spring nuts (S)

4) Inserire le staffe per i pannelli (U) e le staffe per il piano di lavoro (T) nelle traverse a 2 e 3 vie (H).  
4) Insert the plates for the panels (U) and worktop (T) in the two and three-way crossbars (H)

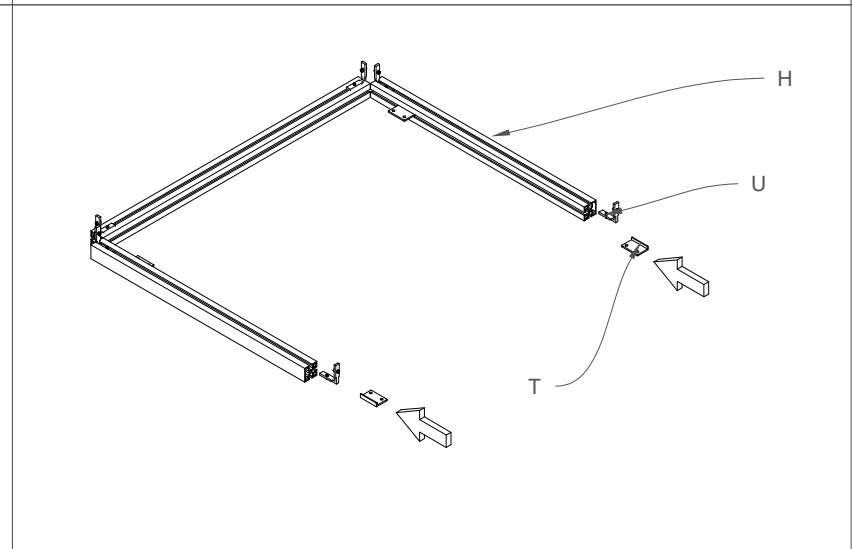
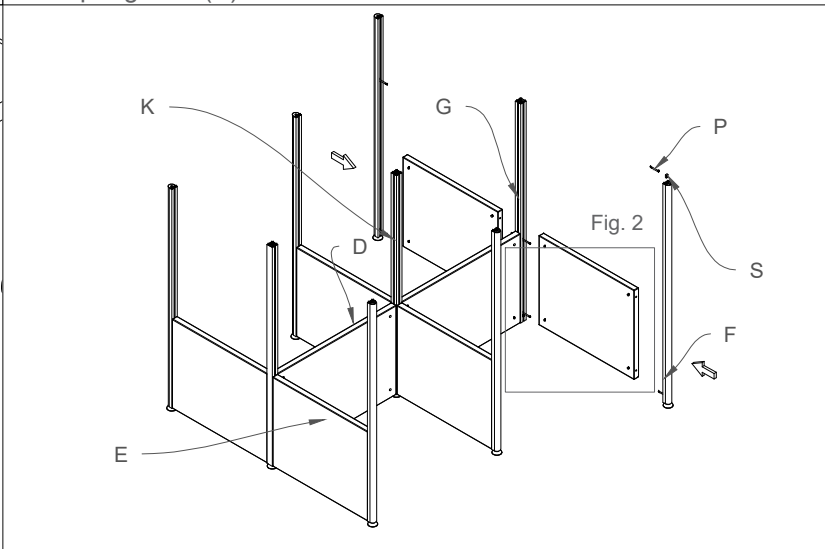
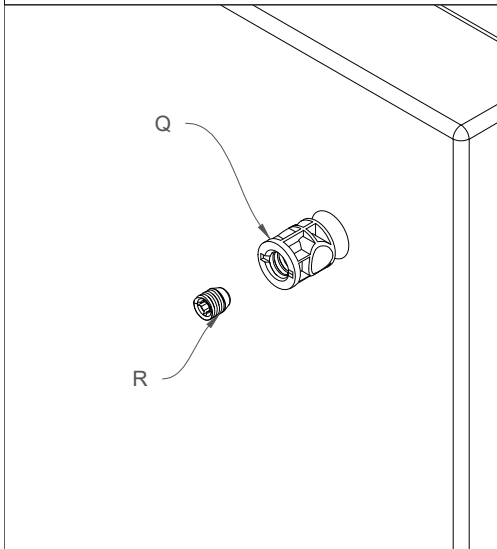

Fig.1 Serraggio del grano (R) nei barilotti (Q).  
 Fig.1 Tighten the threaded screws (R) in the barrels (Q)

5) Inserire le traverse (H) nei montanti (G, K e F).  
 5) Insert the crossbars (H) in the columns (G, K and F)

6) Inserire i fianchi e i frontali fonoassorbenti superiori (B e C) nei montanti (F, K e G) tramite i tiranti (P) con i dadi a molla (S).  
 6) Insert the sides and upper frontal sound absorbing panels (B and C) in the columns (F, K and G) by means of the tie-rods (P) and spring nuts (S)

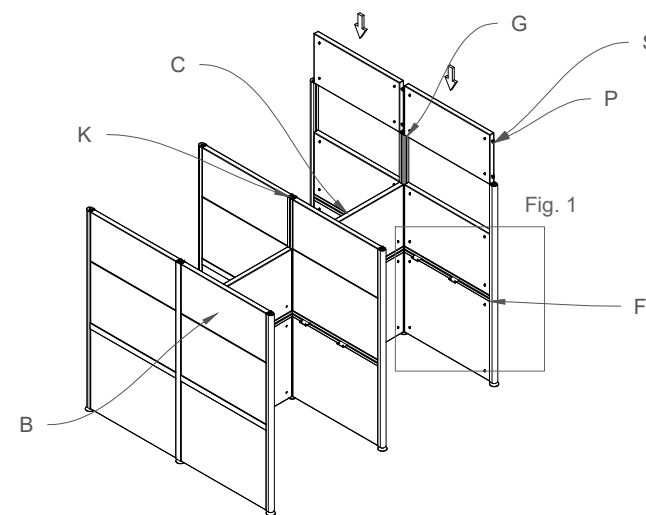
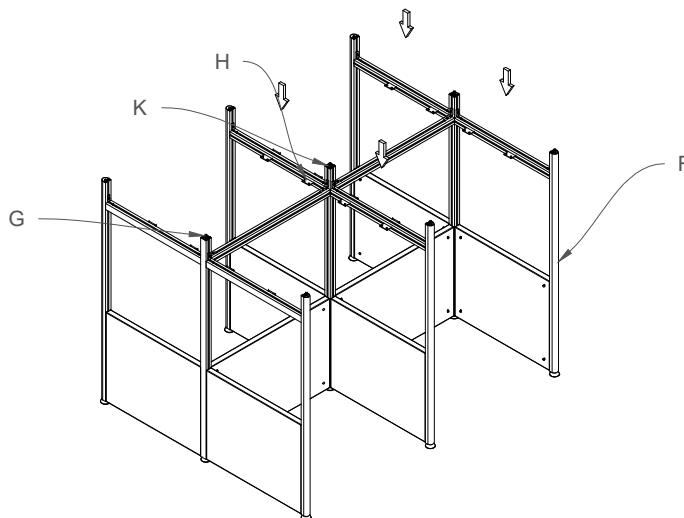
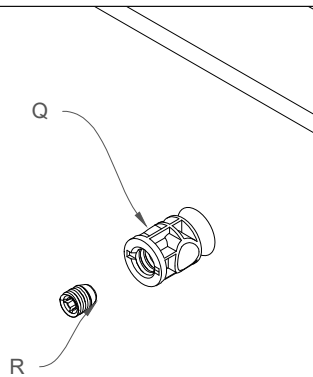

Fig.2 Serraggio delle traverse (H) nei montanti.  
 Fig.2 Tighten the crossbars (H) in the columns

7) Inserire la traversa a 2 vie (J) nei montanti a 3 e 4 vie (G e K).  
 7) Insert the two-way crossbar (J) in the three and four-way columns (G and K)

8) Inserire il pannello in metacrilato (I) nella traversa (J) e nei montanti (G e K) e fissarlo tramite la gomma (L).  
 8) Insert the methacrylate panel (I) in the crossbar (J) and in the columns (G and K), fasten it by means of the rubber (L)

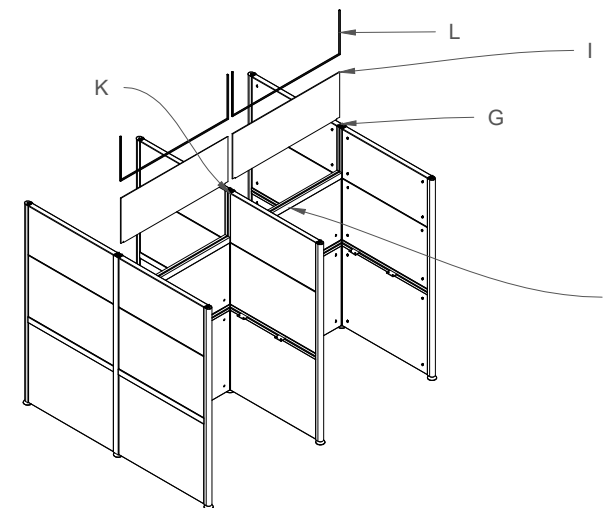
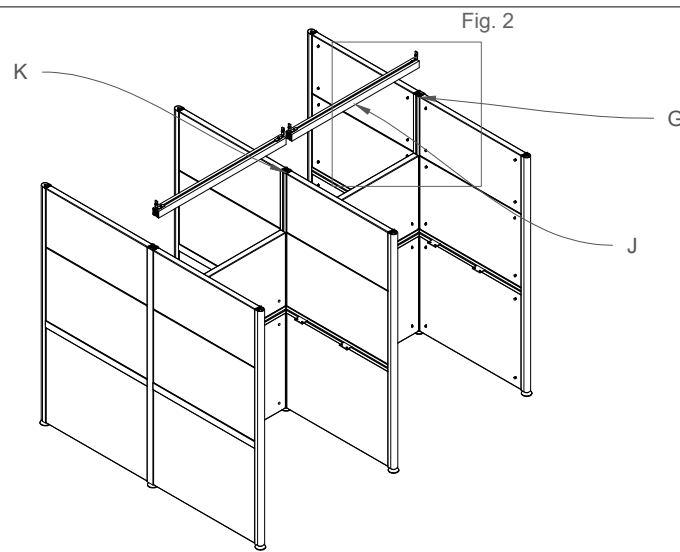
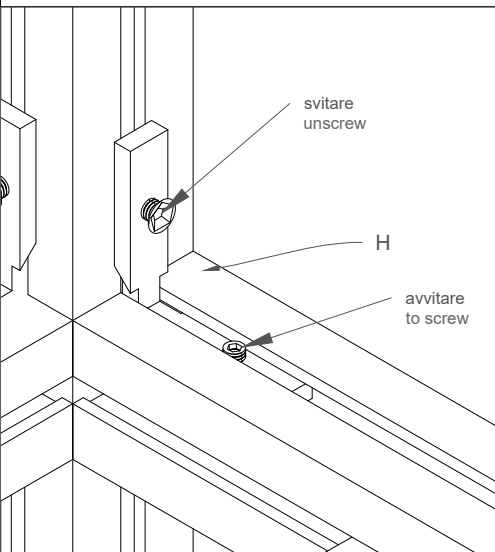

Fig.1 Inserimento del piano di lavoro (A) tramite le staffe (T) e le viti (V).  
 Fig.1 Insert the worktop (A) by means of the plates (T) and screws (V)

9) Inserire il piano da lavoro (A) e i tappi per i montanti (Z) e i tappi copri barilotti (O).

9) Insert the worktop (A), the column and barrel caps (Z and O)

