











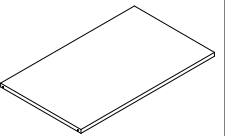
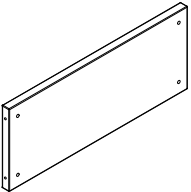
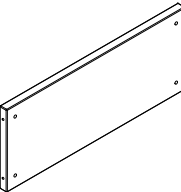
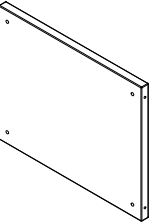

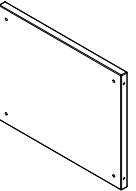

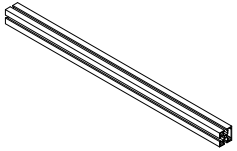
Ferramenta Hardware	Componenti Components								
Rondella (M) 	Washer (M) n°9		Piano da lavoro (A) Worktop (A)		Pannello laterale superiore (B) Upper lateral panel (B)		Pannello frontale superiore (C) Upper front panel (C)		Pannello laterale inferiore (D) Lower lateral panel (D)
Piedino (N) 	Foot (N) n°9		Pannello frontale inferiore (E) Lower front panel (E)		Montante stondato 1 via (F) Rounded one-way column (F)		Montante 3 vie (G) Three-way column (G)		Traversa 3 vie (H) Three-way crossbar (H)
Tappi copri barilotti (O) 	Barrel caps (O) n°56								
Tirante 10x46 (P) 	Tie-rod 10x46 (P) n°56								
Barilotto 14x17.5 (Q) 	Barrel 14x17.5 (Q) n°56								
Grano 8x12 (R) 	Threaded screw 8x12 (R) n°56								
Dado a molla (S) 	Spring nut (S) n°56								
Piastrine per traverse (T) 	Plates for crossbars (T) n°16								
Piastrine per piano (U) 	Plates for tops (U) n°16								
Viti 4x30 (V) 	Screws 4x30 (V) n°32								
Tappi per i montanti (Z) 	Caps for columns (Z) n°9								

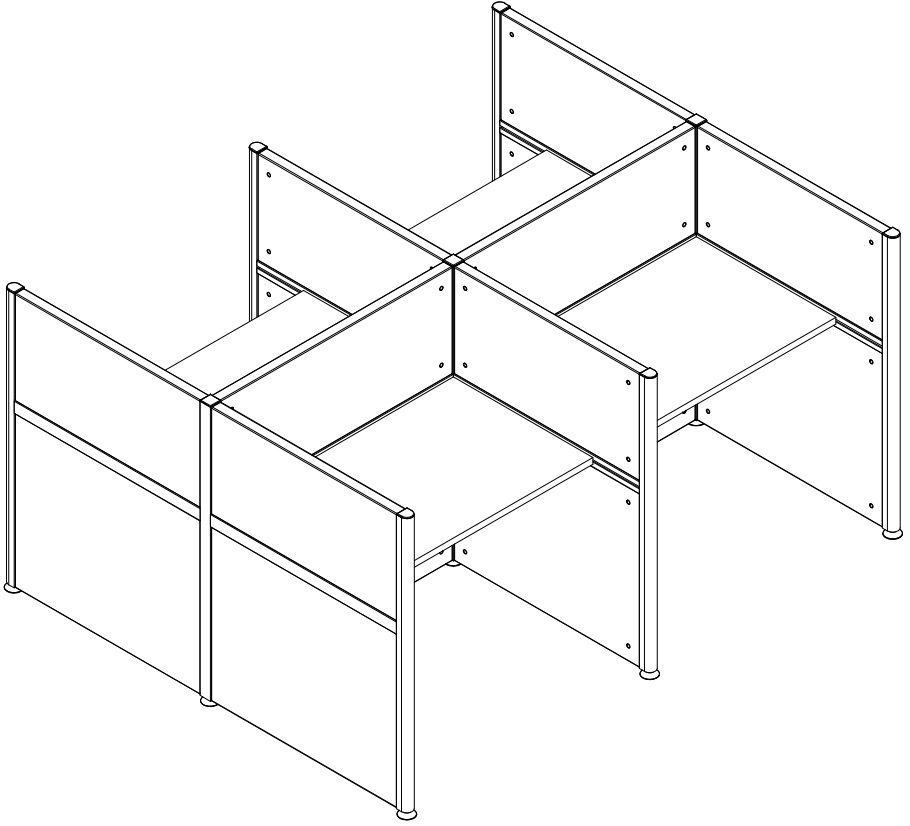
Fig.1 Inserimento del piedino (N) con la rondella (M).
Fig.1 Insert the foot (N) by means of the washer (M)

1) Inserire il piedino (N) con la rondella (M) nei montanti a 3 e 1 via (G, I e F).

1) Insert the foot (N) by means of the washer (M) in the one, three or four-way columns (F, I and G)

2) Inserire il barilotti (Q) e i tiranti (P) con il dado a molla (S) nei pannelli fonoassorbenti superiori (B e C).

2) Insert the barrels (Q) and the tie-rods (P) by means of the spring nut (S) in the upper sound absorbing panels

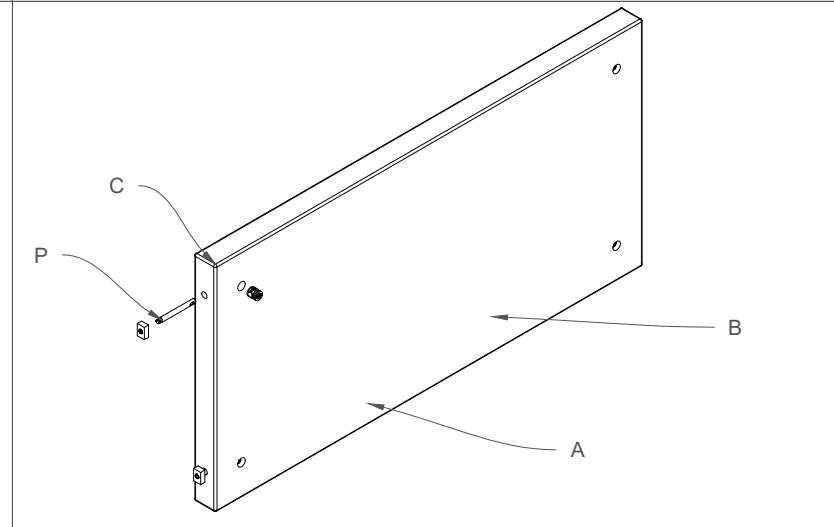
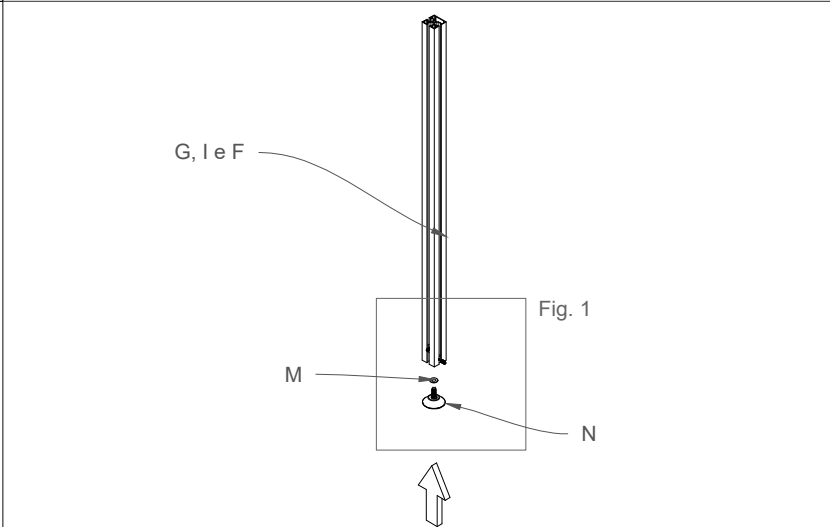
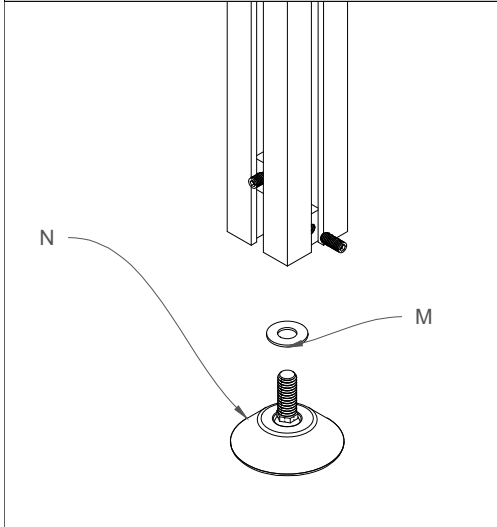

Fig.2 Serraggio del grano (R) nei barilotti (Q).
Fig.2 Tighten the threaded screws (R) in the barrels (Q)

3) Inserire i fianchi e i frontali fonoassorbenti inferiori (D e E) nei montanti (F, I e G) tramite i tiranti (P) con i dadi a molla (S).
3) Insert the sides and lower frontal sound absorbing panels (D and E) in the columns (F, I and G) by means of the tie-rods (P) and spring nuts (S)

4) Inserire le staffe per i pannelli (U) e le staffe per il piano di lavoro (T) nelle traverse (H).
4) Insert the plates for the panels (U) and worktops (T) in the crossbars (H)

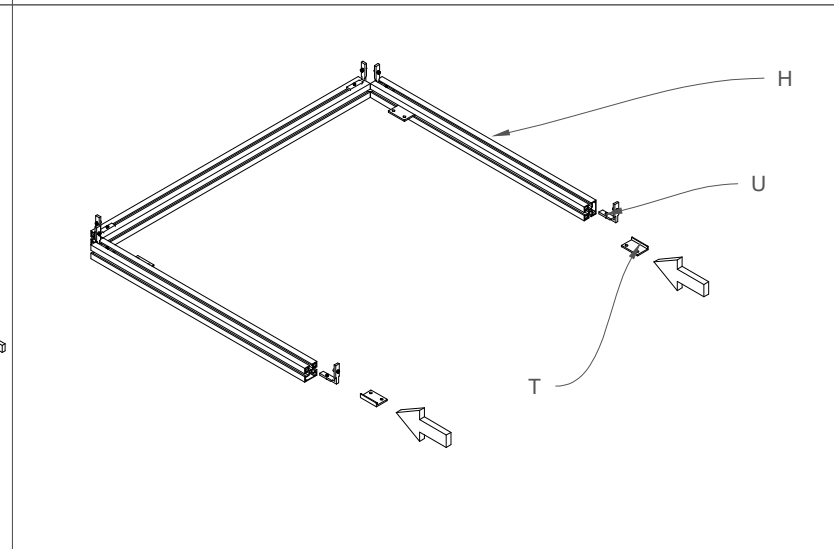
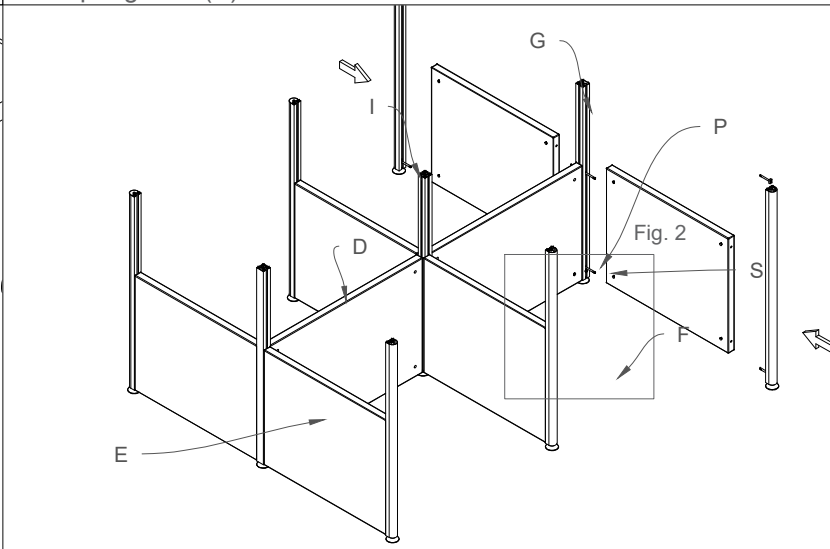
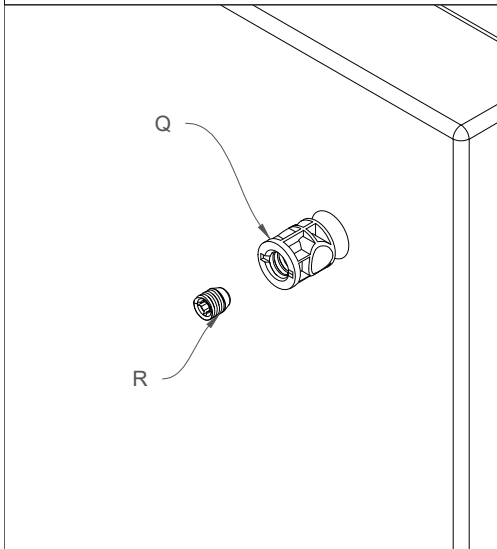
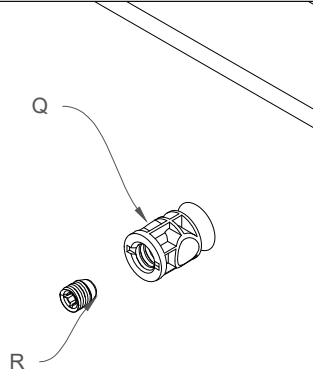
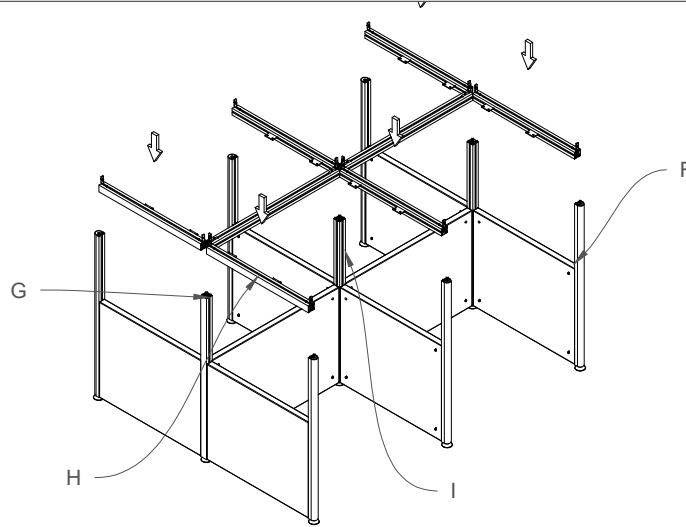

Fig.1 Serraggio del grano (R) nei barilotti (Q).
Fig.1 Tighten the threaded screws (R) in the barrels (Q)



5) Inserire le traverse (H) nei montanti (G, I e F).
5) Insert the crossbars (H) in the columns (G, I and F)



6) Serraggio delle traverse (H) nei montanti.
6) Tighten the crossbars (H) in the columns

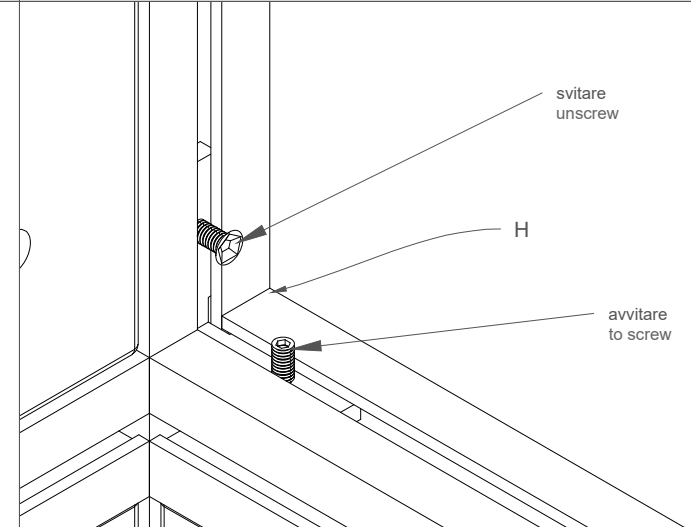
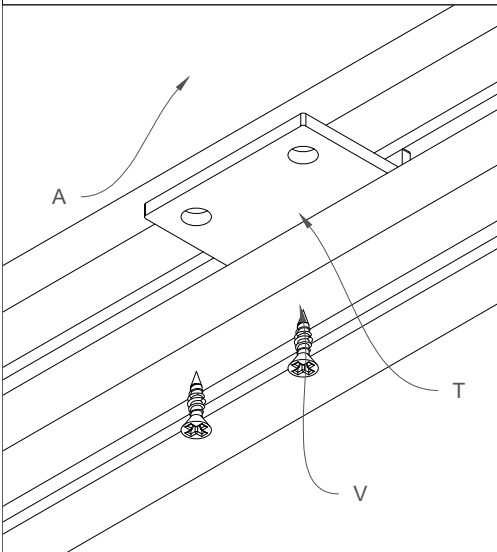
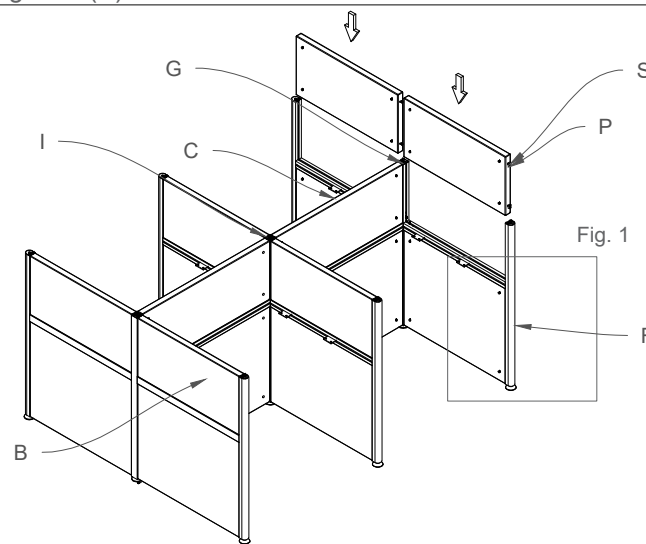

Fig.2 Inserimento del piano di lavoro (A) tramite le staffe (T) e le viti (V).
Fig.2 Insert the worktop (A) by means of the plates (T) and screws (V)



7) Inserire i fianchi e i frontali fonoassorbenti superiori (B e C) nei montanti (F, I e G) tramite i tiranti (P) con i dadi a molla (S).
7) Insert the sides and upper frontal sound absorbing panels (B and C) in the columns (F, I and G) by means of the tie-rods (P) and spring nuts (S)



8) Inserire il piano da lavoro (A) e i tappi per i montanti (Z) e i tappi copri barilotti (O).
8) Insert the worktop (A), the column and barrel caps (Z and O)

