


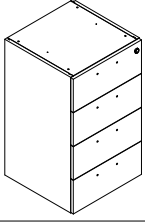
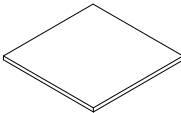




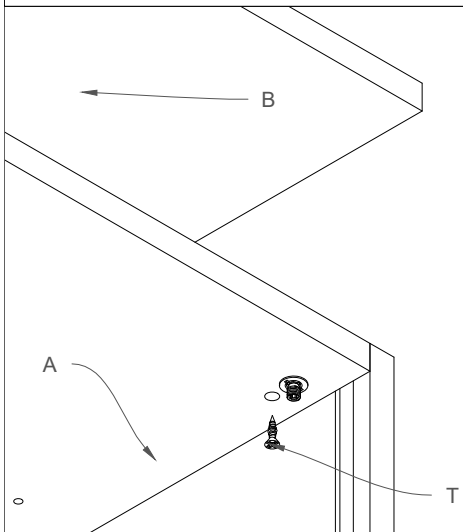
Ferramenta Hardware	Componenti Components		Cassettiera (A) Chest of drawers(A)		Top (B) Finished top (B)				
Chiave esagonale Hexagonal key	n°1								
Viti 4x30 (T) Screws 4x30 (T)	n°4								
Piedino (U) Foot (U)	n°4								
Bullone 4x12 (V) Bolt 4x12 (V)	n°8								
Maniglie (Z) Handles (Z)	n°4								

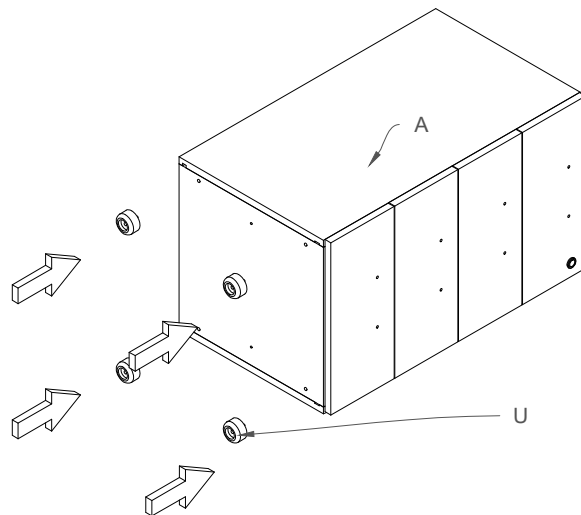


Fig.1 Inserimento del top (B) nella cassettera (A) tramite i bulloni (V).
Fig.1 Insert the finished top (B) in the chest of drawers (A) by means of the bolts (V)



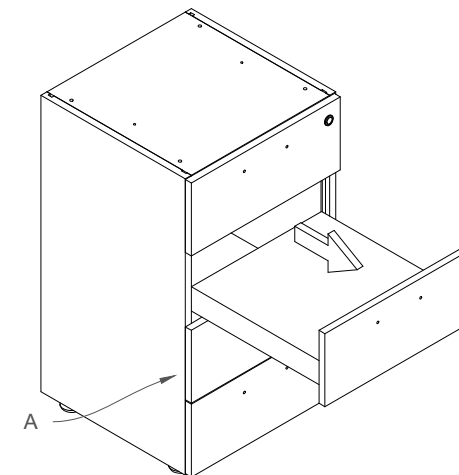
1) Posizionare la cassettera (A) su un fianco e inserire i piedini (U).

1) Position the chest of drawers (A) on one side, insert the feet (U)



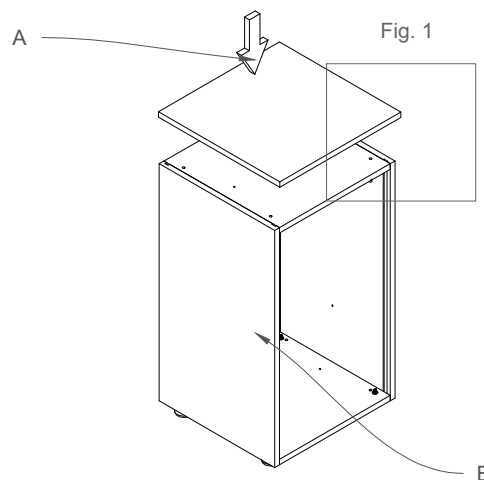
2) Ruotare la cassettera (A) ed estrarre i cassetti.

2) Rotate the chest of drawers (A), extract the drawers



3) Inserire il top (B) nella cassettera (A)

3) Insert the finished top (B) in the chest of drawers (A)



4) Inserire nuovamente i cassetti nella cassettera (A).

4) Insert the drawers in the chest of drawers (A)

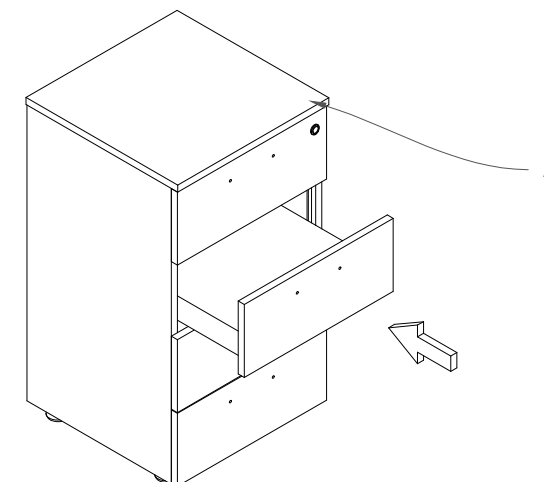


Fig.1 Inserimento delle maniglie (Z) nella cassettera (A) tramite i bulloni (V).
 Fig.1 Insert the handles (Z) in the chest of drawers (A) by means of the bolts (V)

5) Inserire le maniglie (Z) nella cassettera (A).

5) Insert the handles (Z) in the chest of drawers (A)

