













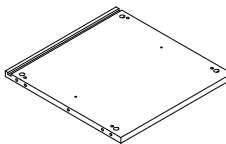
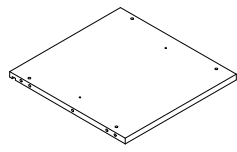

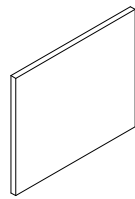
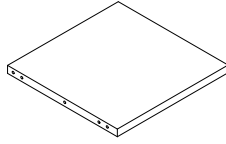
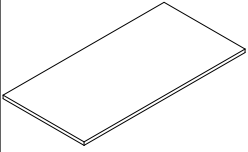
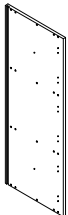

Ferramenta Hardware	Componenti Components								
Viti di giunzione 5x27 (I) 	Junction Screws 5x27 (I) n°2		Fianco (A) Side (A)		Base (B) Base (B)		Cappello (C) Top (C)		Retro (D) Back panel (D)
Viti 4x30 (L) 	Screws 4x30 (L) n°4		Ante (E) Doors (E)		Ripiani strutturali (F) Structural shelves (F)		Top (G) Finished top (G)		Fianco per ante (H) Side for doors (H)
Spina 8x30 (N) 	Wooden pin 8x30 (N) n°56								
Tirante 7x33.5 (O) 	Tie-rod 7x33.5 (O) n°24	Chiave esagonale 	Hexagonal key n°1						
Bariolotto 14x14 (P) 	Barrel 14x14 (P) n°24								
Grano 8x8 (Q) 	Threaded screw 8x8 (Q) n°24								
Basetta (R) 	Hinge base (R) n°12								
Viti 3.5x18 (S) 	Screws 3.5x18 (S) n°36								
Cerniere (T) 	Hinge (T) n°12								
Piedino (V) 	Foot (V) n°8								
Push and pull (Z) 	Push and pull (Z) n°6								

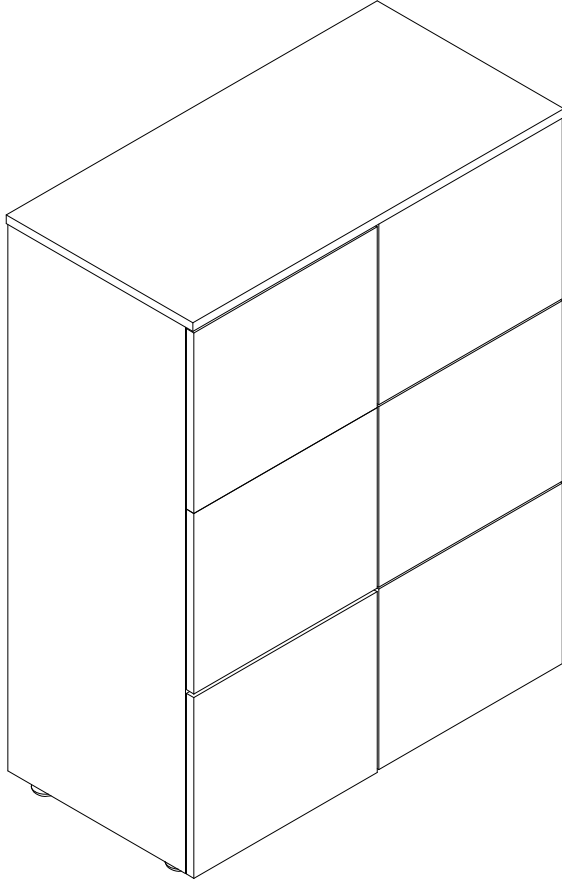
Fig.1 Serraggio dei grani (Q) nei barilotti (P)
 Fig.1 Tighten the threaded screws (Q) in the barrels (P)

1) Posizionare il fianco per ante (H) sul pavimento, inserendo tramite le spine (N), barilotti (P) e i tiranti (O) la base (B), i ripiani strutturali (F) e il cappello (C).
 1) Rotate the side for doors (H) on the floor, insert the base (B), structural shelves (F) and top (C) by means of the wooden pins (N), barrels (P) and tie-rods (O)

2) Inserire il retro (D) nella fresata, effettuata sul fianco per ante (H) e sulla base (B) e cappello (C).
 2) Insert the back panel (D) in the slot of the side for doors (H), the base (B) and top (C).

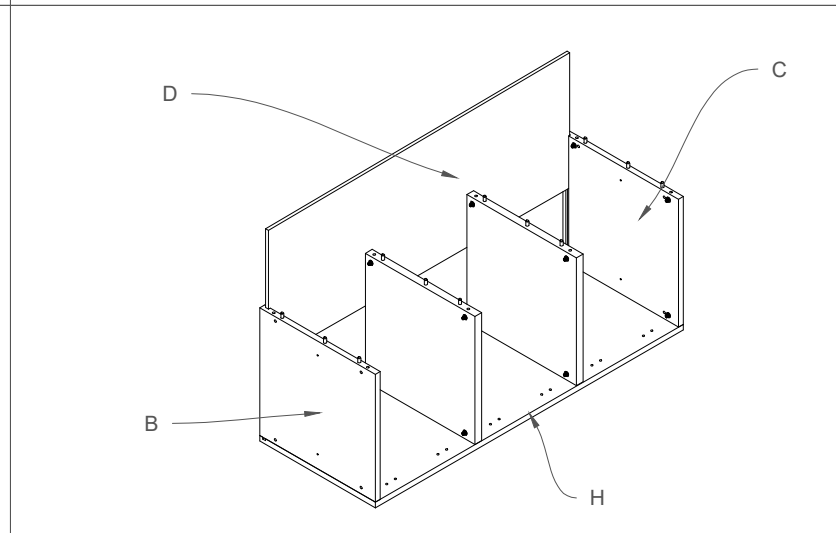
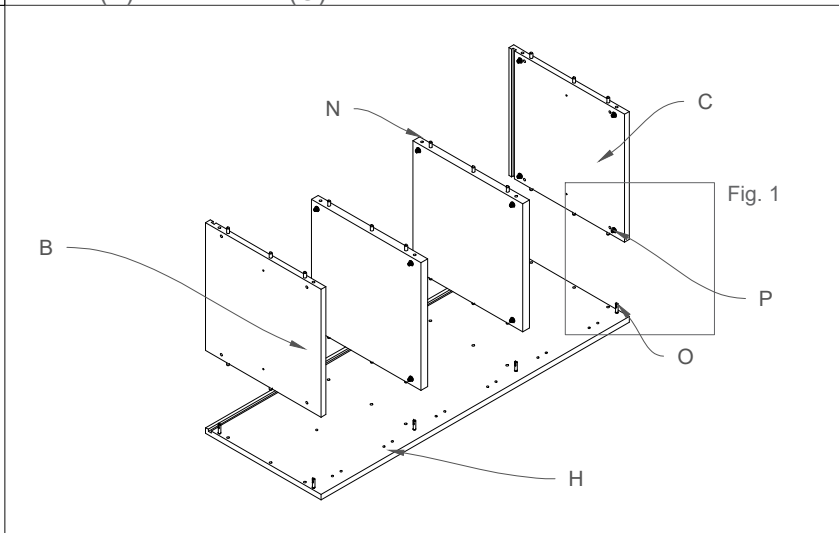
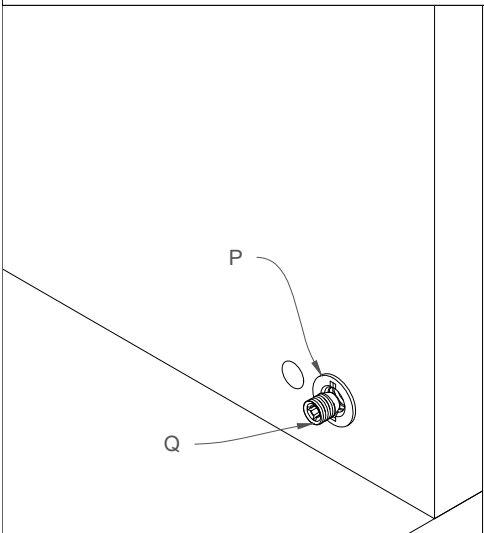

Fig.2 Inserimento delle basette (R) tramite le cerniere (T) e le viti (S)
 Fig.2 Insert the hinge bases (R) by means of the hinges (T) and screws (S)

3) Inserire il fianco (A) tramite spine (N) e tiranti (O) e inserire i piedini (V) nella base (B).
 3) Insert the side (A) by means of the wooden pins (N) and tie-rods (O), insert the feet (V) in the base (B)

4) Inserire 1 o 2 ante (E) nel fianco (H) tramite le basette (R), le cerniere (T) e le viti (S).
 4) Insert 1 or 2 doors (E) in the side (H) by means of the hinge bases (R), hinges (T) and screws (S)

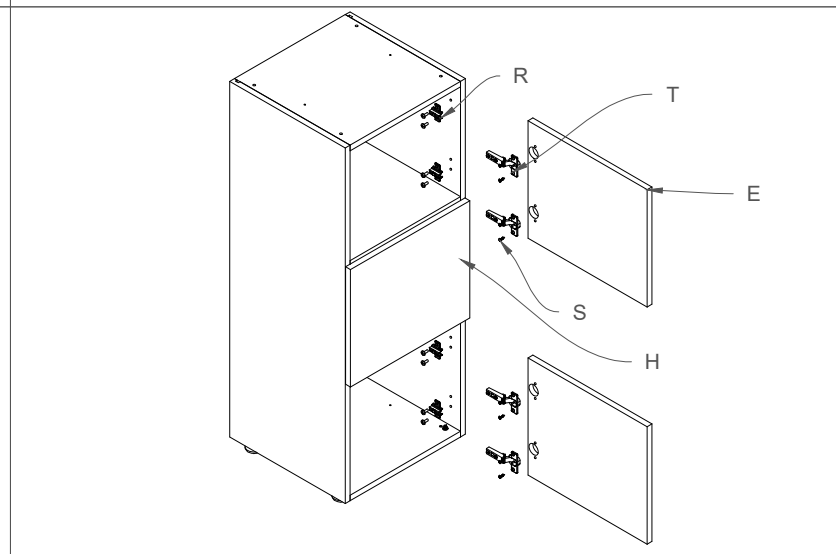
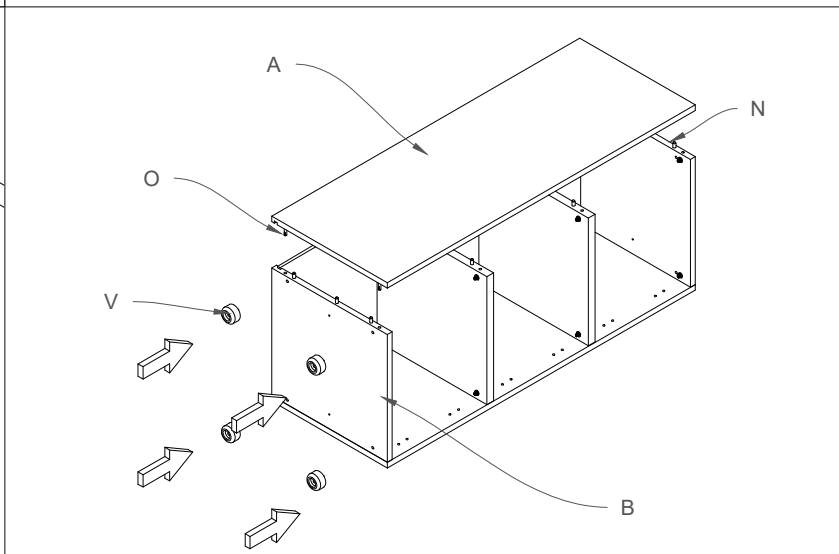
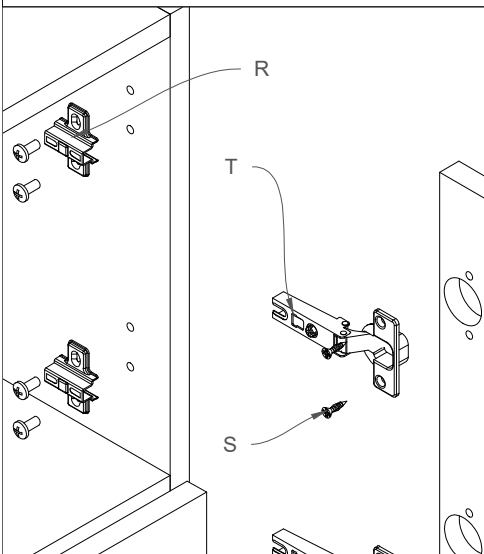

Fig.1 Inserimento del push and pull (Z) nel fianco (A) tramite le viti (S).
 Fig.1 Insert the push and pull (Z) in the side (A) by means of the screws (S)

5) Inserire il push and pull (Z) nel fianco (A) per aprire l'anta (E).
 5) Insert the push and pull (Z) in the side (A) to open the door (E)

6) Unire i lockers tramite le viti di giunzione (I).
 6) Unite the lockers by means of the junction screws (I)

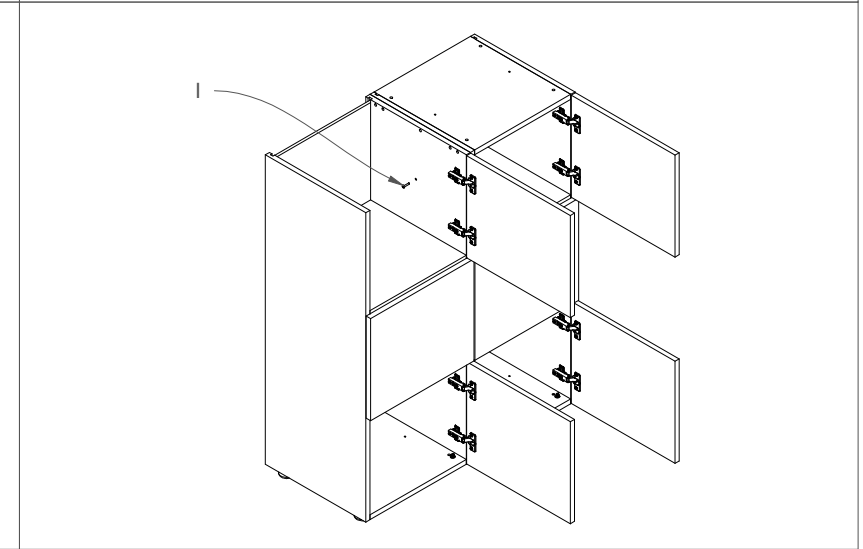
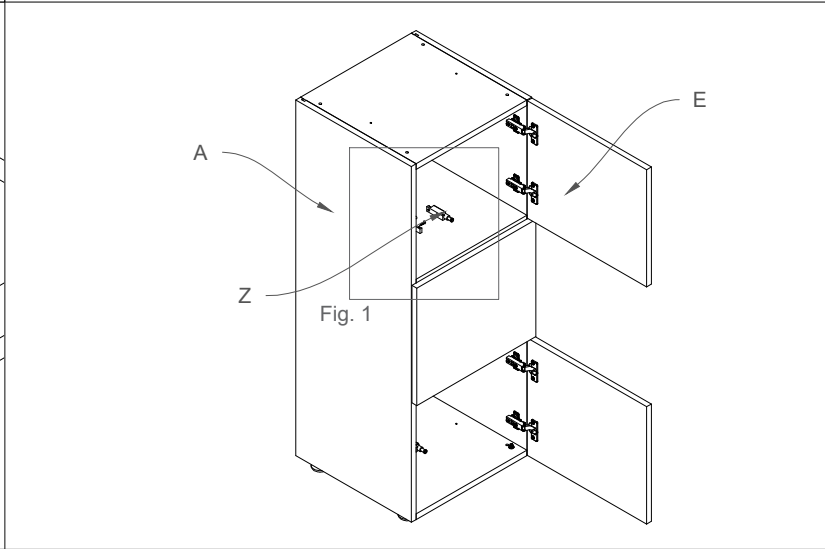
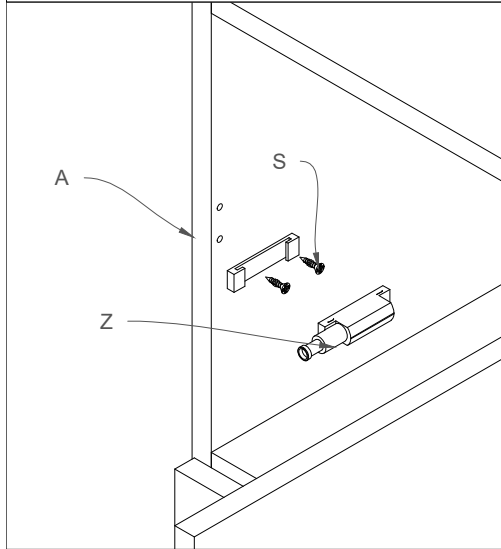

Fig.2 Inserire le viti (L) attraverso le perforature del cappello (C) e forare finché non si aggancia il top (G).
 Fig.2 Insert the screws (L) in function to the pre-drilled holes in the top (C) and perforate until the finished top is fastened (G).

7) Posizionare il top (G) sul cappello (C) .
 7) Position the finished top (G) above the top (C) .

