

Fig.1 Posizionare spine (S), barilotti(U),tiranti(V) nei fianchi(B e C)
 Fig.1 Position the pins (S), barrels (U) and tie-rods (V) in the sides (B and C)

1) Posizionare le spine (S), i barilotti (U) e piedini (T) nei fianchi (B e C).
 1) Position the pins (S), barrels (U) and feet (T) in the sides (B and C)

2) Posizionare i barilotti (U) nella traversa (D).
 2) Position the barrels (U) in the cross panel (D)

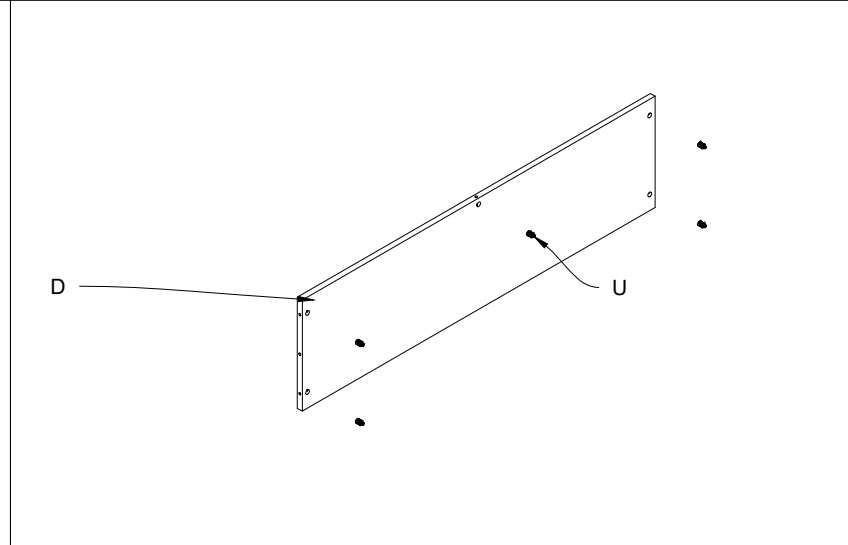
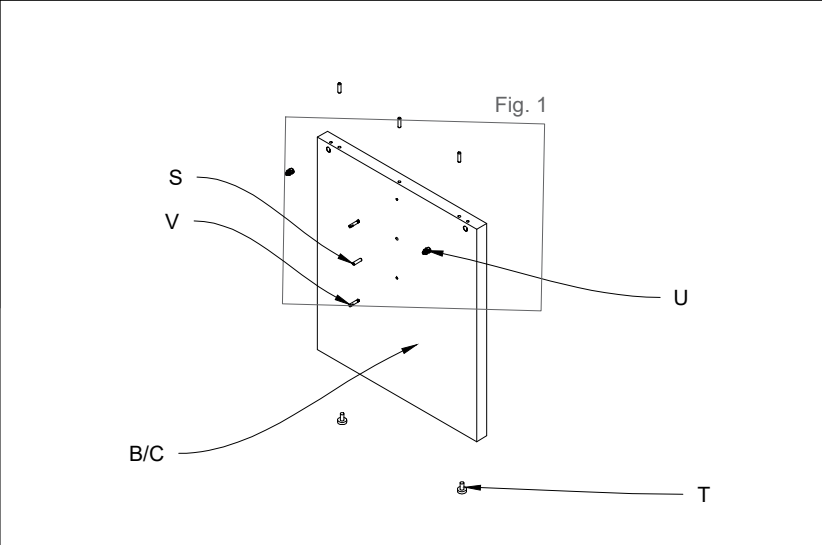
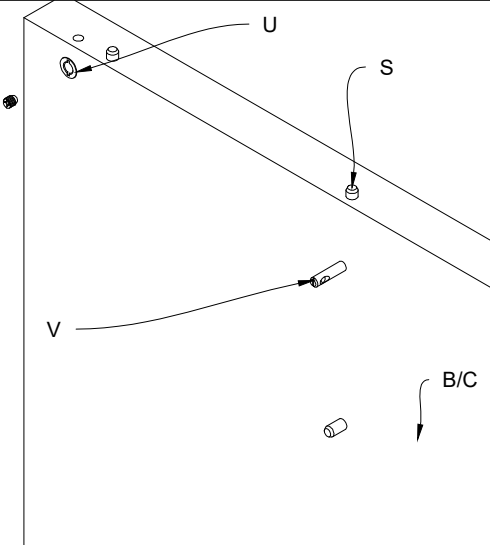

Fig.2 Posizionare i tiranti (V) nel piano (A).
 Fig.2 Position the tie-rods (V) in the top (A)

4) Unire i fianchi (B e C) alla traversa (D) tramite le spine (S) e i tiranti (V)
 4) Unite the sides (B and C) to the cross panel (D) by means of the pins (S) and tie-rods (V)

3) Posizionare i tiranti (V) nel piano (A).
 3) Position the tie-rods (V) in the top (A)

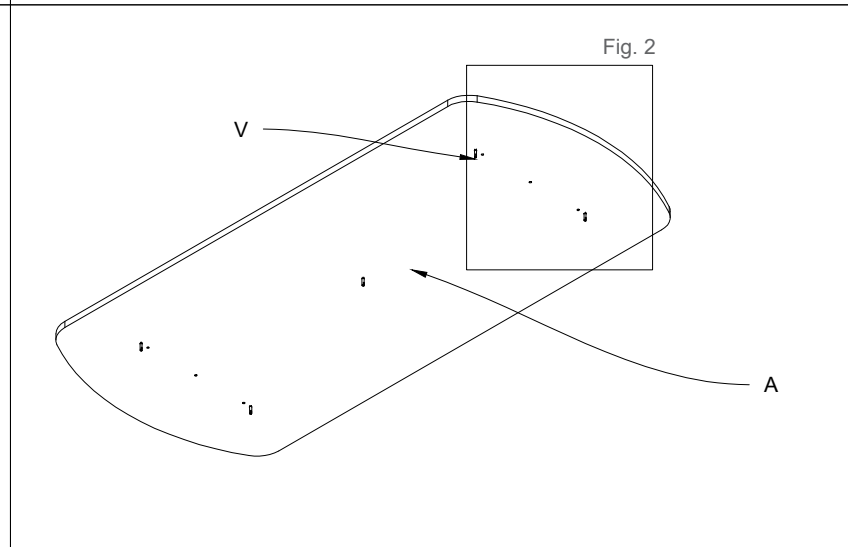
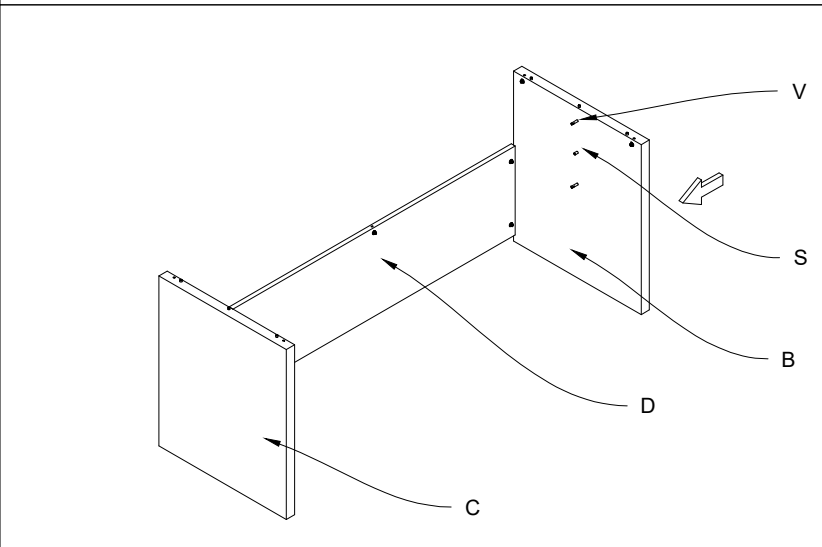
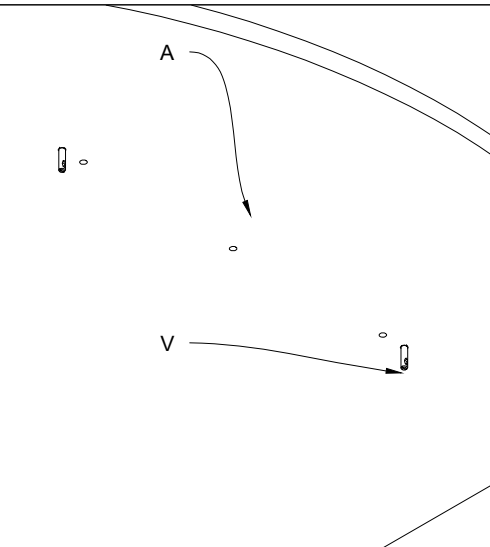
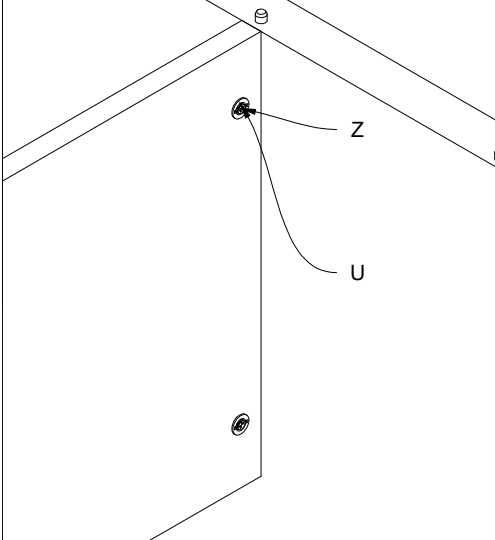
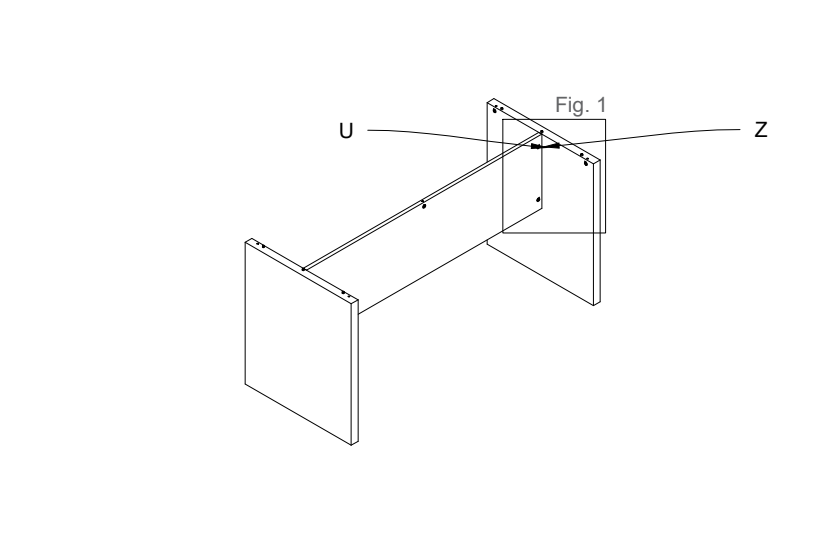

Fig.1 Serraggio grani (Z) nei barilotti (U)
 Fig.1 Tighten the treaded screws (Z) in the barrels (U)



5) Serraggio grani (Z) nei barilotti (U)
 5) Tighten the treaded screws (Z) in the barrels (U)



6) Posizionare il Piano (A), sopra la struttura e agganciarlo tramite le spine (S) e i tiranti (V)
 6) Position the top (A) on top of structure and fasten it by means of the pins (S) and tie-rods (V)

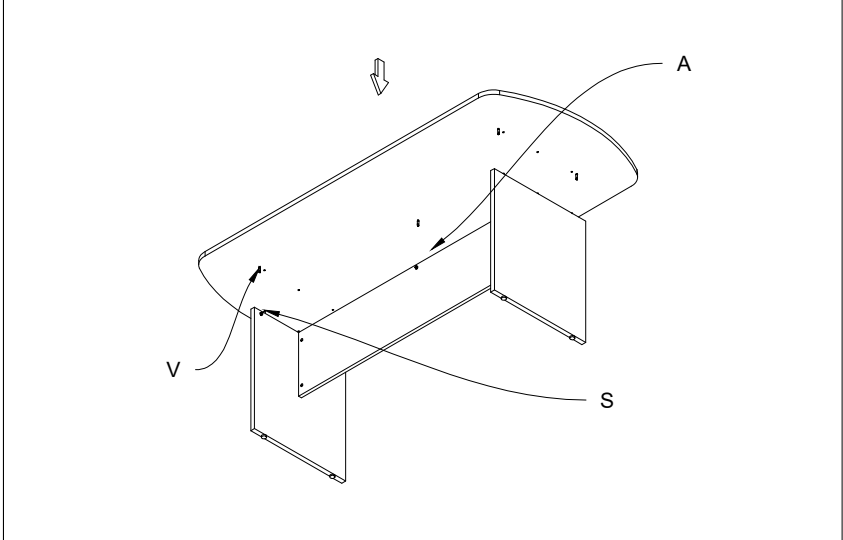
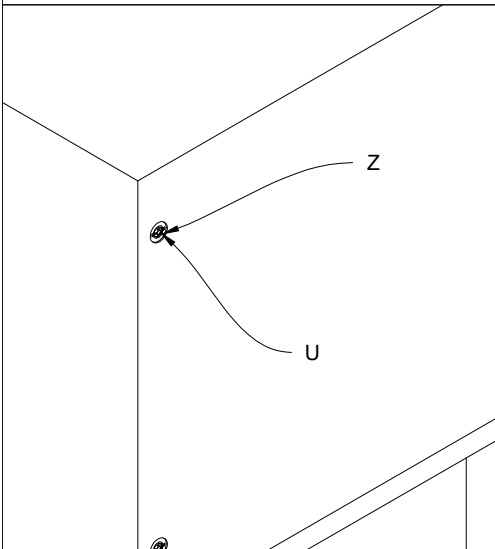

Fig.2 Serraggio grani (Z) nei barilotti (U)
 Fig.2 Tighten the treaded screws (Z) in the barrels (U)



7) Serraggio grani (Z) nei barilotti (U)
 7) Tighten the treaded screws (Z) in the barrels (U)

