

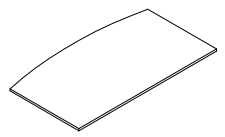

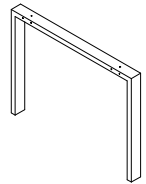

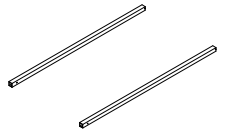

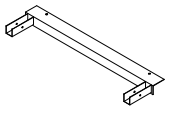



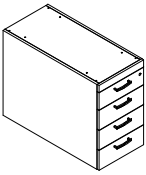



Ferramenta Hardware	Componenti Components									
Chiave esagonale Hexagonal key	n°1			Piano (A) Top (A)		Gamba (B) Leg (B)		Travi (C) Crossbars (C)		Elemento di giunzione (D) Junction element (D)
Maniglia (L) Handle (L)	n°4			Cassettiera (E) Chest of drawers (E)						
Bullone 4x25 (M) Bolt 4x25 (M)	n°8									

Distanziale (N) Spacer (N)	n°2		Bullone 6x30 (X) Bolt 6x30 (X)	n°4	
Paracolpo (O) Strut (O)	n°4		Piedini diam. 25 (Y) Feet diam. 25 (Y)	n°4	
Piedini diam. 35 (P) Feet diam. 35 (P)	n°2		Bullone 6x60 (Z) Bolt 6x60 (Z)	n°2	
Rondella sp.16 (Q) Washer sp.16 (Q)	n°4				
Dado 6 MA (S) Nut 6 MA (S)	n°4				
Bullone 6x16 (T) Bolt 6x16 (T)	n°4				
Bullone 6x20 (U) Bolt 6x20 (U)	n°12				
Bullone 6x45 (V) Bolt 6x45 (V)	n°4				

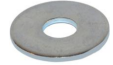
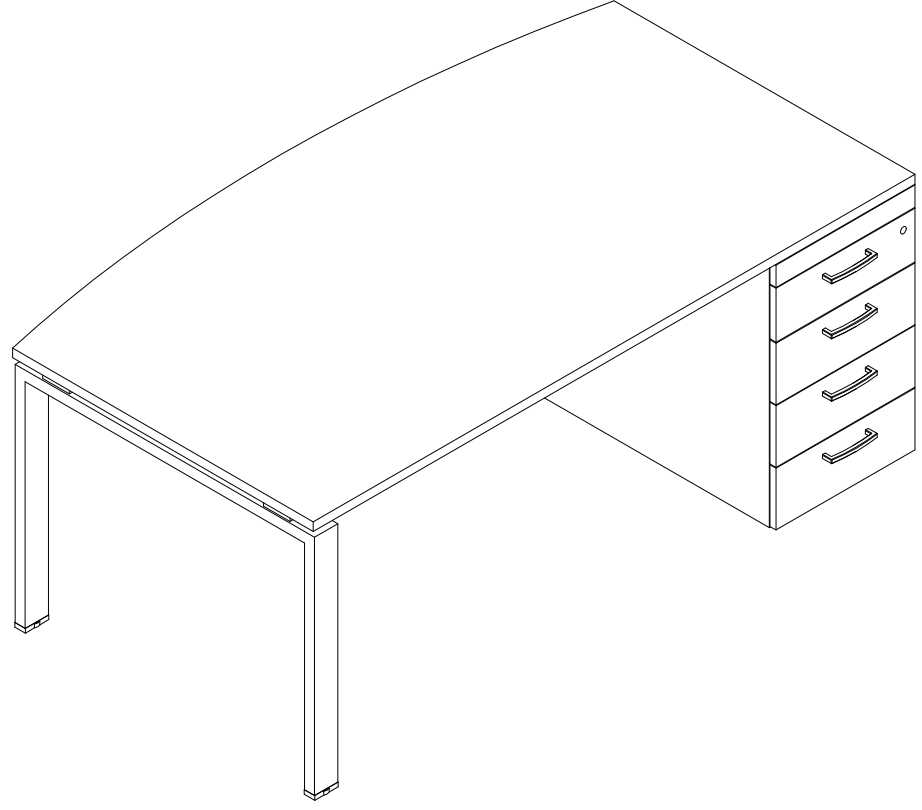

Fig.1 Fissare i bulloni (X) tra elemento di giunzione (D) e la cassettera (E)
 Fig.1 Fasten the bolts (X) between the junction element (D) and chest of drawers (E)

1) Inserire i piedini (Y) nella cassettera (E).
 1) Insert the feet (Y) in the chest of drawers (E).

2) Inserire le maniglie (L) nella cassettera (E) tramite i bulloni (M).
 2) Insert the handles (L) in the chest of drawers (E) by means of the bolts (M)

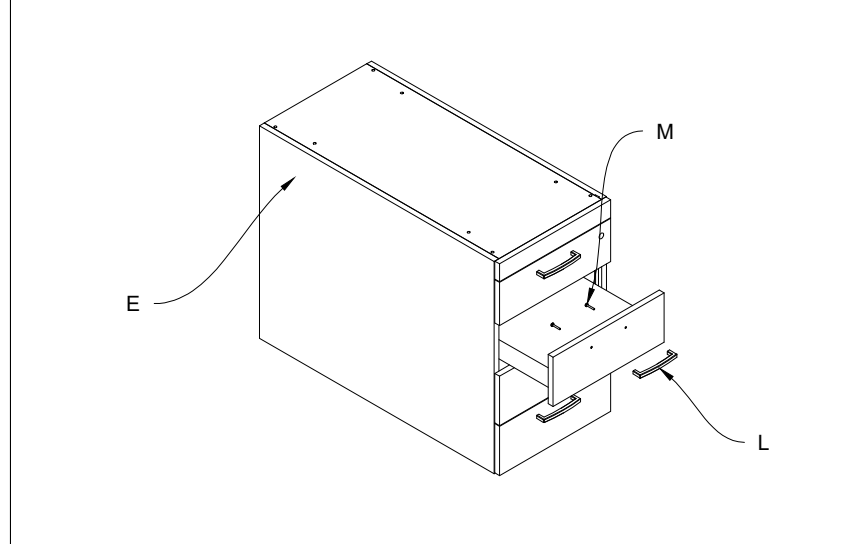
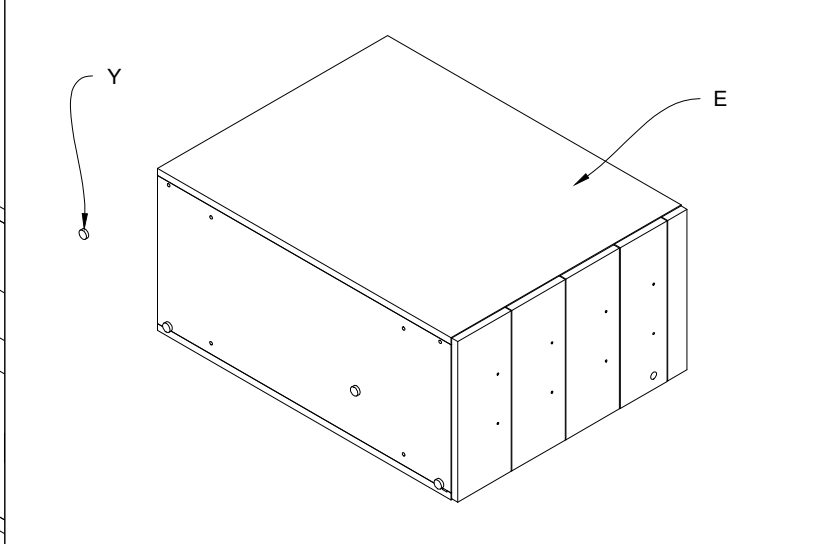
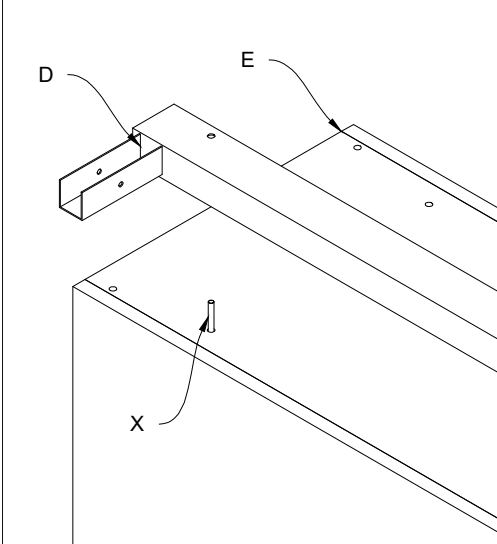

Fig.2 Fissare i bulloni (U) nei distanziali (N) delle gambe (B).
 Fig.2 Fasten the bolts (U) in the spacers (N) of the legs (B).

3) Unire l'elemento di giunzione (D) alla cassettera (E) tramite i bulloni (X).
 3) Unite the junction element (D) to the chest of drawers (E) by means of the bolts (X)

4) Posizionare i distanziali (N) e i piedini (P), nelle gambe (B)
 4) Position the spacers (N) and feet (P) in the legs (B)

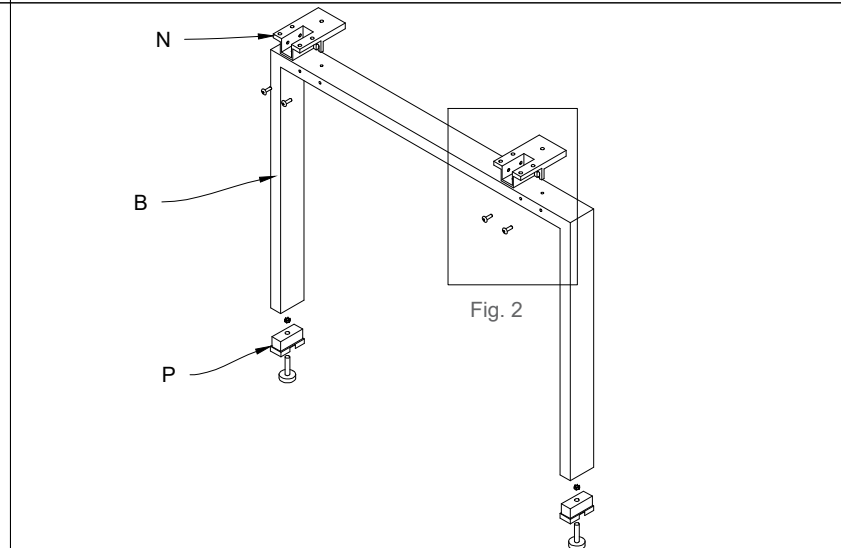
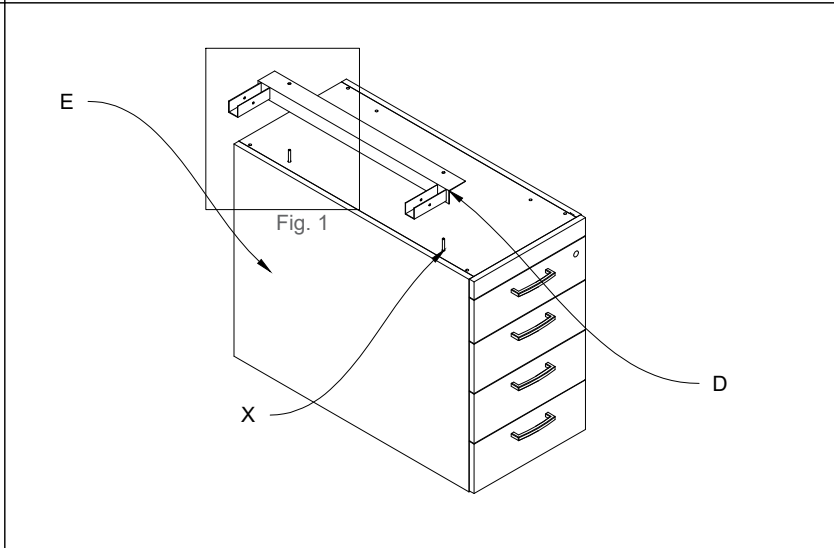
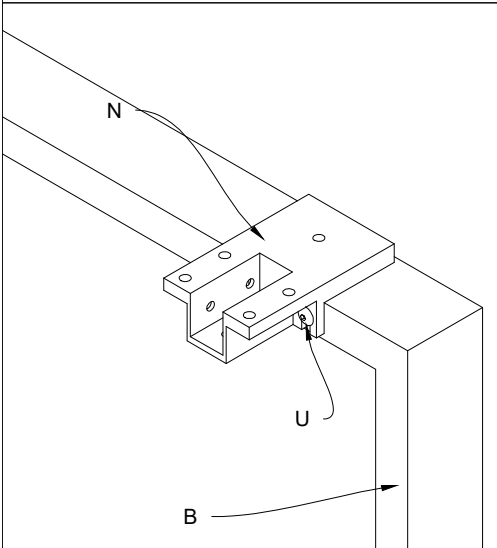

Fig.1 Fissare i bulloni (T e V) tra l'elemento di giunzione (D) e le travi(C) tramite dadi (S) e rondelle(Q).

Fig.1 Fasten the bolts (T and V) between the junction element (D) and the crossbars (C) by means of the nuts (S) and washers (Q).

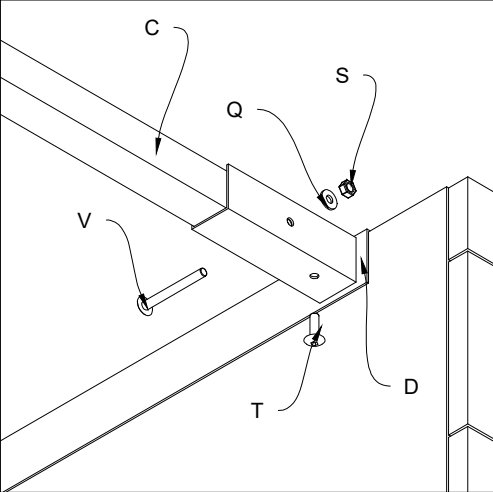
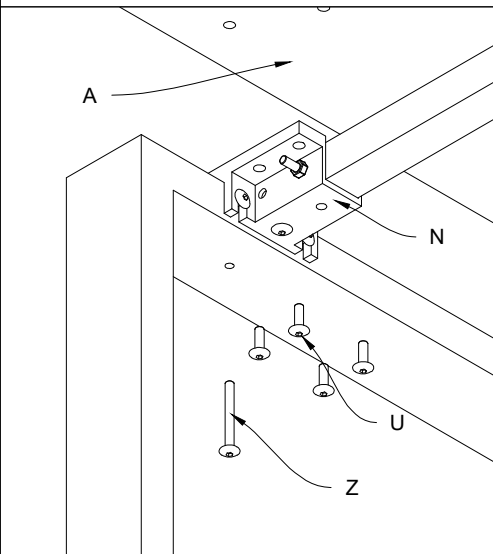

Fig.2 Fissare i bulloni (U e Z) nei distanziali (N) con il piano (A) e la struttura.

Fig.2 Fasten the bolts (U and Z) to the spacers (N) in the top (A) and structure.



2) Posizionare le travi (C) sui distanziali (N) e l'elemento di giunzione (D) e inserire i paracolpi (O).

2) Position the crossbars (C) on the spacers (N) and the junction element (D), insert the struts (O)

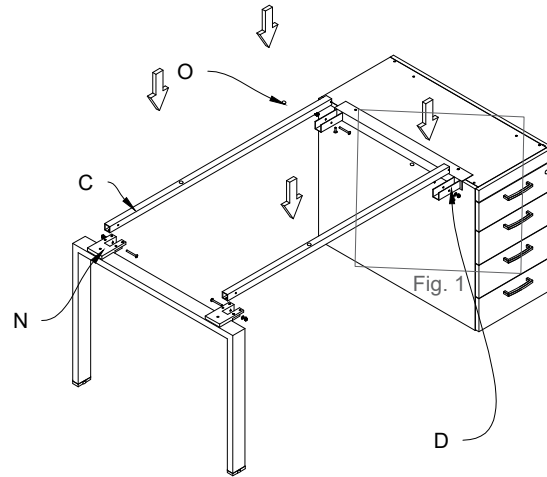

3) Posizionare il piano (A) sopra la struttura.

3) Position the top (A) on top of the structure.

