

Schema di montaggio Assembly diagram

Ferramenta Componenti

Hardware Components

Maniglia (T) Handle (T)



n°4

Bullone da 4x25 (U) Bolt 4x25 (U)



n°8

Bullone da 6x28 (V) Bolt 6x20 (V)



n°4

Piedini regolabili diam.=35 (Z) Adjustable feet diam.=35 (Z)



n°4

Chiave esagonale Hexagonal key



n°1

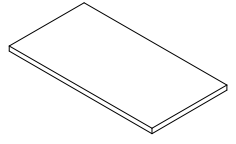

Top (A)
Top (A)

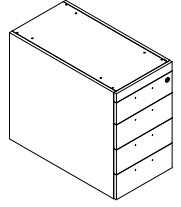

Cassettiera (B)
Chest of drawer (B)

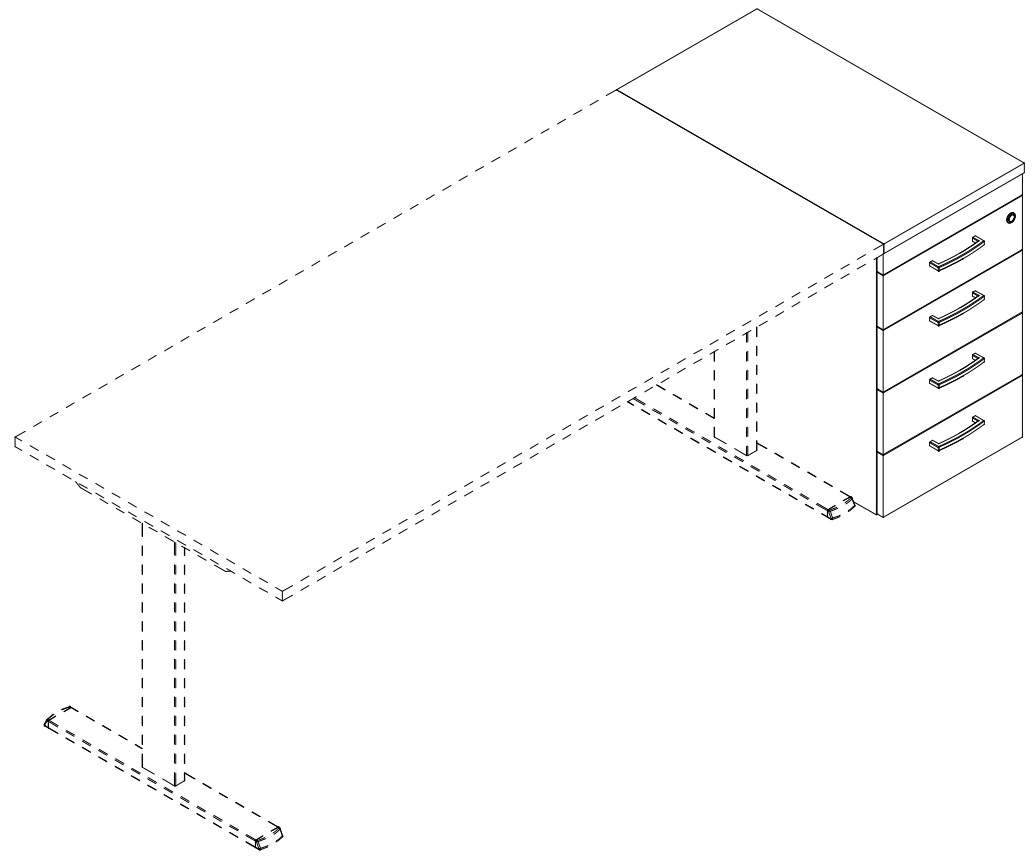

Fig.1 Inserimento del top (A) nella cassettera (B) tramite i bulloni (V).
Fig.1 Insert the top (A) in the chest of drawers (B) by means of the bolts (V)

1) Inserire i piedini (Z) sotto la cassettera (B).
1) Insert the feet (Z) under the chest of drawers (B)

2) Inserire il top (A) tramite i bulloni nella cassettera (B).
2) Insert the top (A) in the chest of drawers (B) by means of the bolts.

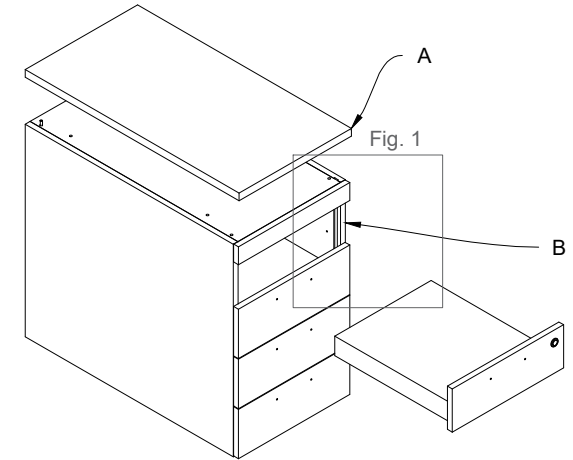
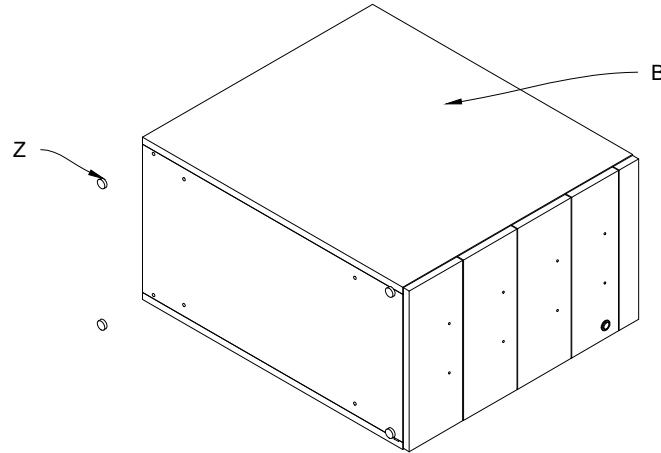
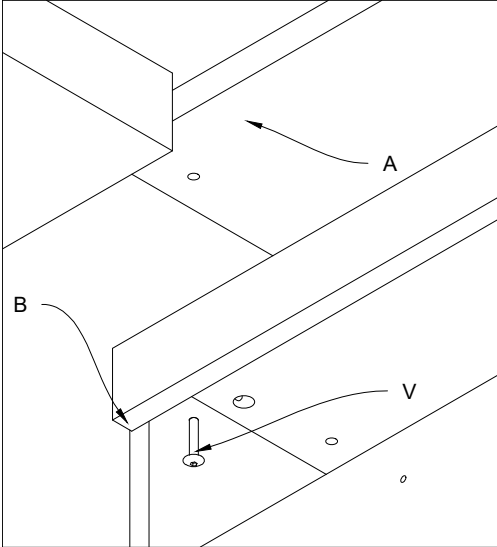

Fig.2 Inserimento delle maniglie (T) nella cassettera (B) tramite i bulloni (U).
Fig.2 Insert the handles (T) in the chest of drawers (B) by means of the bolts (U)

3) Inserire le maniglie (T) nella cassettera (B).
3) Insert the handles (T) in the chest of drawers (B)

4) Accostare la cassettera (B) al piano desiderato.
4) Put the chest of drawers (B) next to the top

