
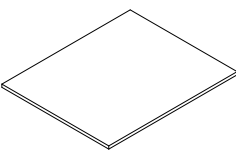

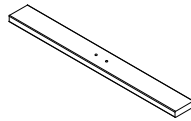

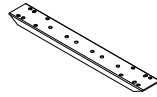
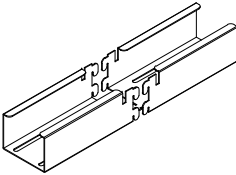




Ferramenta Hardware	Componenti Components							
Chiave esagonale Hexagonal key 	n°1	Piano (A) Top (A) 		Gamba (B) Leg (B)		Elemento 1 (C) Element 1 (C)		
Bullone 6x20 (T) Bolt 6x20 (T) 	n°8	Elemento di giunzione (E) Junction element (E) 		Prolunghe (F) Extensions (F)				
Bullone 8x25 (U) Bolt 8x25 (U) 	n°4							
Piedini diam. 35 (Z) Feet diam. 35 (Z) 	n°2							

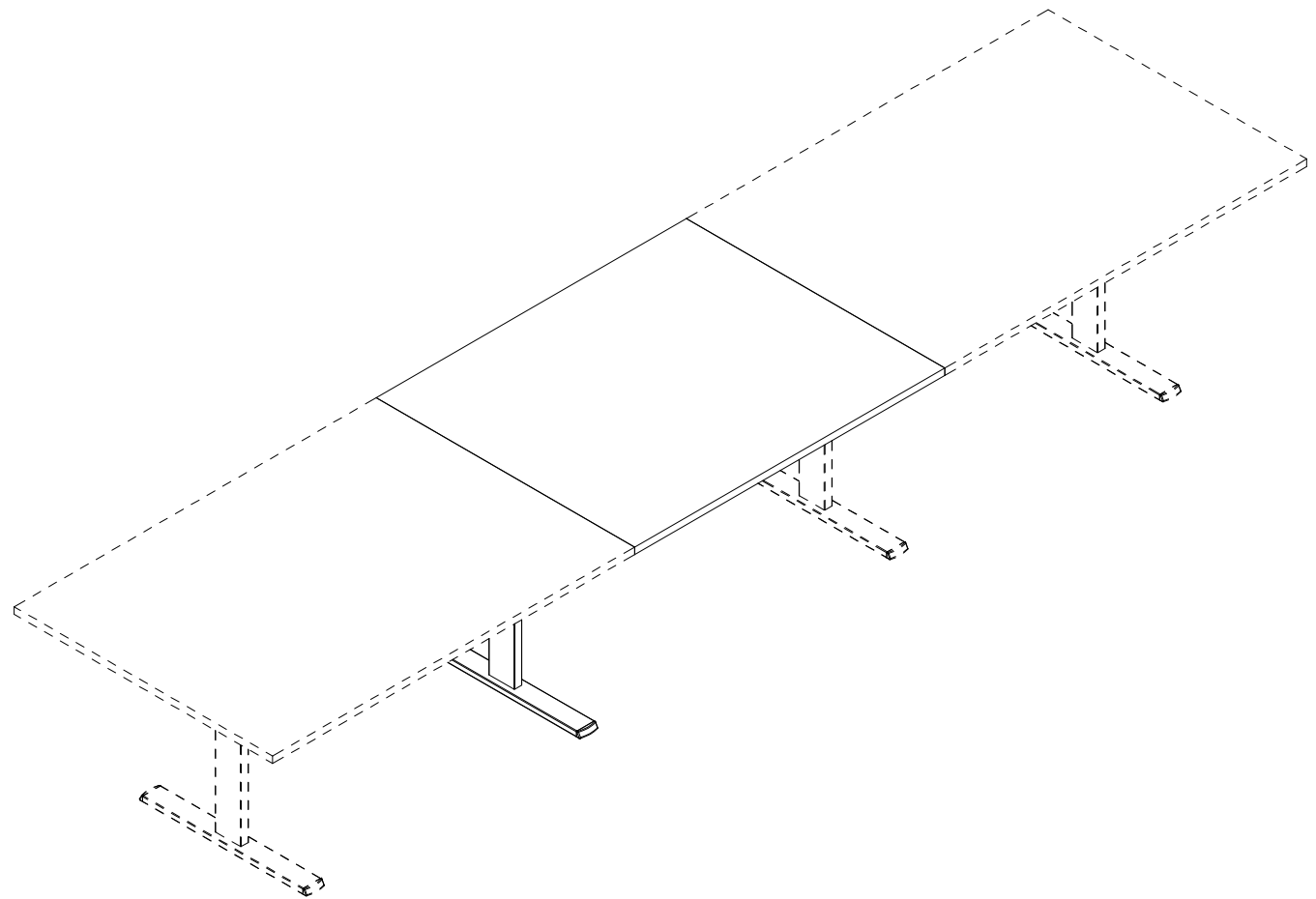


Fig.1 Fissaggio della gamba (B) nell'elemento 1 (C) tramite i bulloni (U).  
Fig.1 Fasten the leg (B) in element 1 (C) by means of the bolts (U).

1) Inserire i piedini (Z) nell'elemento 1 (C).  
1) Insert the feet (Z) in element 1 (C).

2) Inserire la gamba (B) nell'elemento 1 (C).  
2) Insert the leg (B) in element 1 (C).

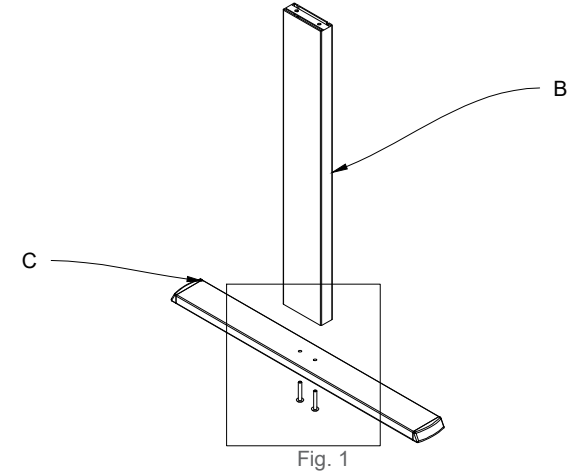
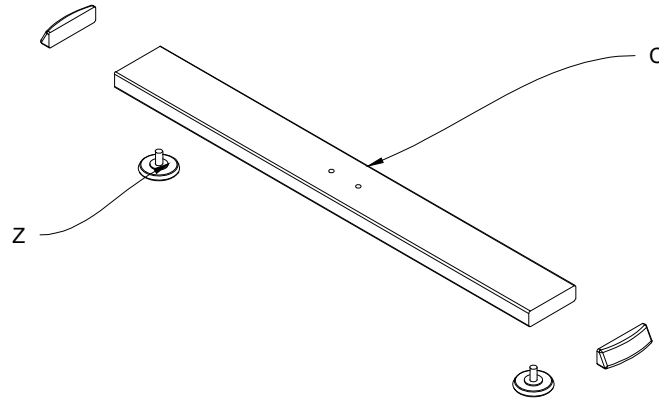
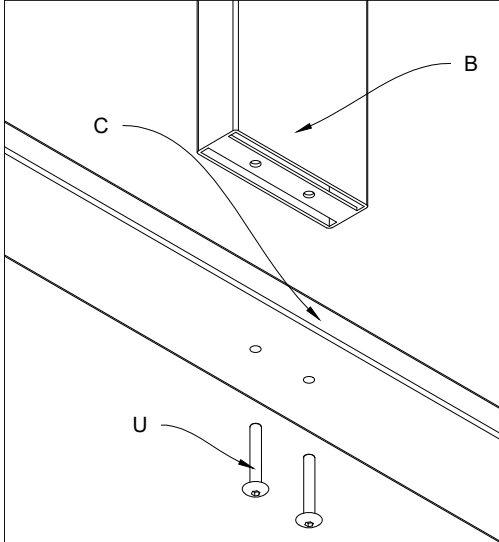


Fig.2 Inserimento dell'elemento di giunzione (E), la prolunga (F) e la gamba nel piano (A) tramite i bulloni (T).  
Fig.2 Insert the junction element (E), extensions (F) and leg in the top (A) by means of the bolts (T)

3) Separare un tavolo riunione con il piano a due pezzi  
3) Separate the meeting table top pieces

4) Inserire la gamba (B) l'elemento 1 (C), l'elemento di giunzione e le prolunghie (F) in modo da collegare le due strutture.  
4) Insert the leg (B), element 1 (C), junction element and extensions (F) in order to unite the two structures

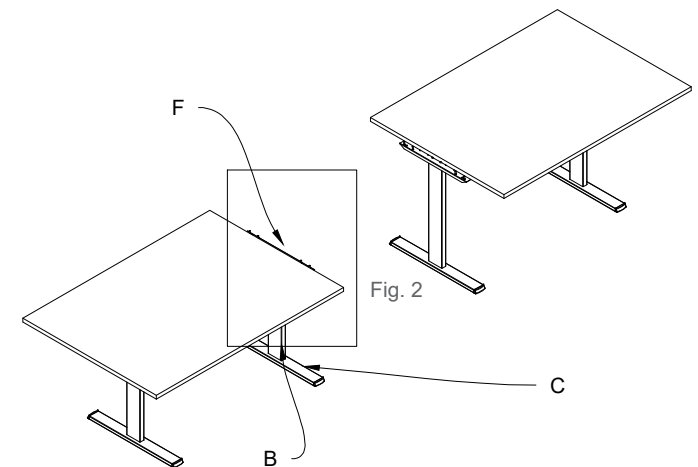
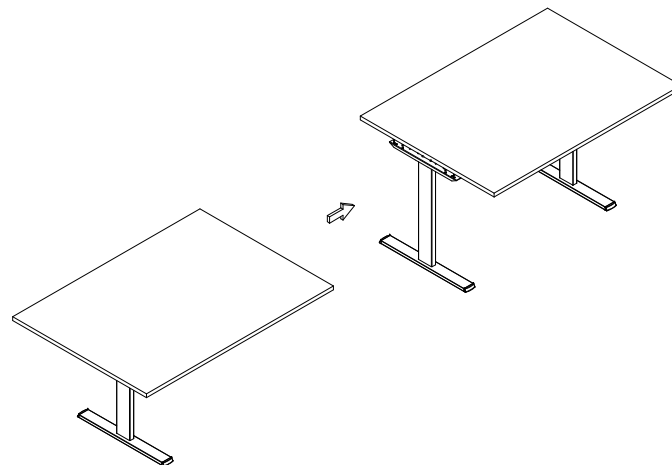
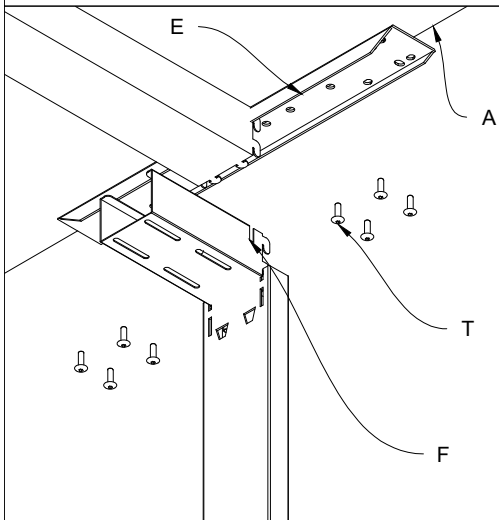
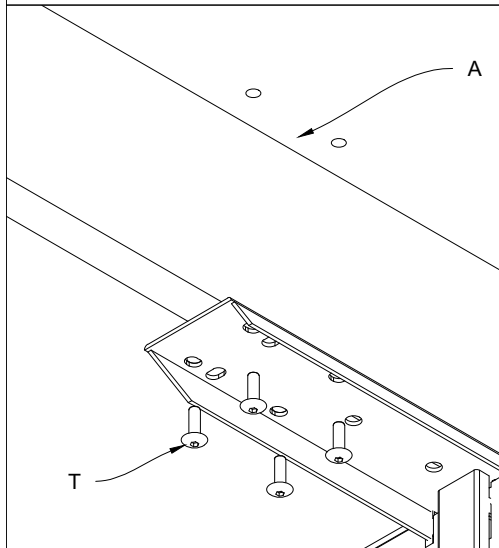


Fig.1 Fissaggio della struttura nel piano (A) tramite i bulloni (T).

Fig.1 Fasten the structure to the top (A) by means of the bolts (T)



5) Inserire il piano (A) nella struttura

5) Insert the top (A) in the structure

