

Fig.1 Inserimento dei tiranti (Z) nel fianco (B)

Fig.1 Insert the tie-rods (Z) in the side (B)

1) Posizionare i tiranti (Z) e i piedini (S) nel fianco (B)

1) Position the tie-rods (Z) and feet (S) in the side (B)

2) Inserire il piano (A) nel fianco (B) tramite i tiranti (Z) e spine (V)

2) Insert the top (A) in the side (B) by means of the tie-rods (Z) and wooden pins (V)

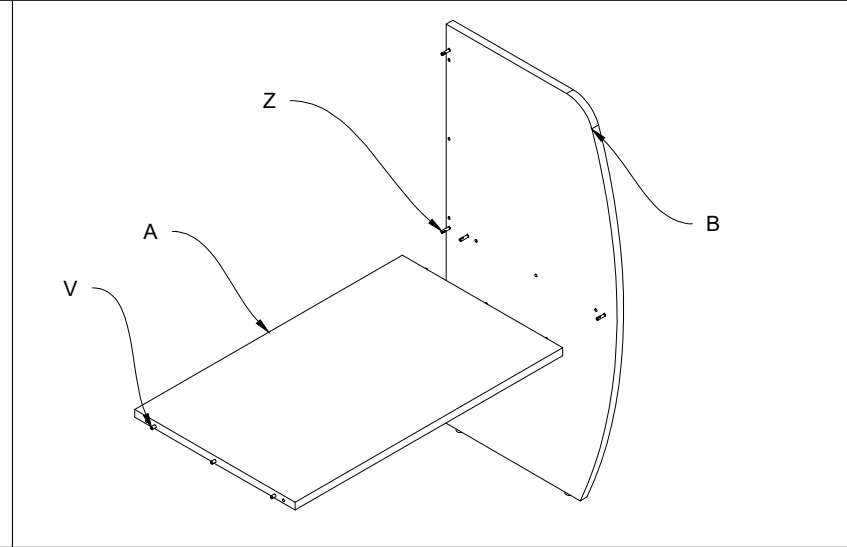
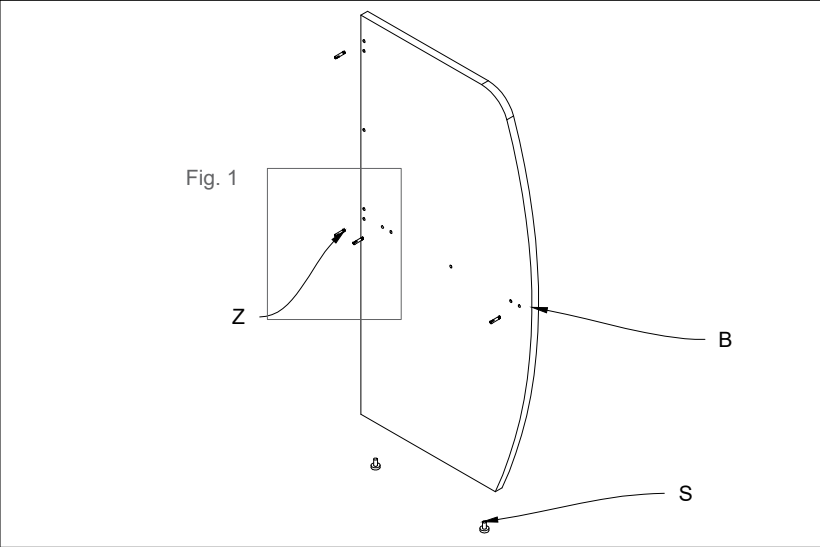
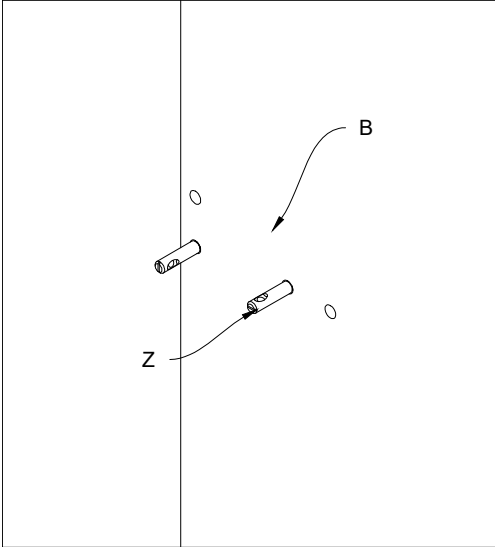

Fig.2 Serrare i grani (U) nei barilotti (T)

Fig.2 Tighten the threaded screws (U) in the barrels (T)

3) Inserire il frontale (C) nel fianco (B) tramite i tiranti (Z) e spine (V).

3) Insert the frontal panel (C) in the side (B) by means of the tie-rods (Z) and wooden pins (V)

4) Separare il fianco esterno dal call autonomo.

4) Separate the side from the independent Call

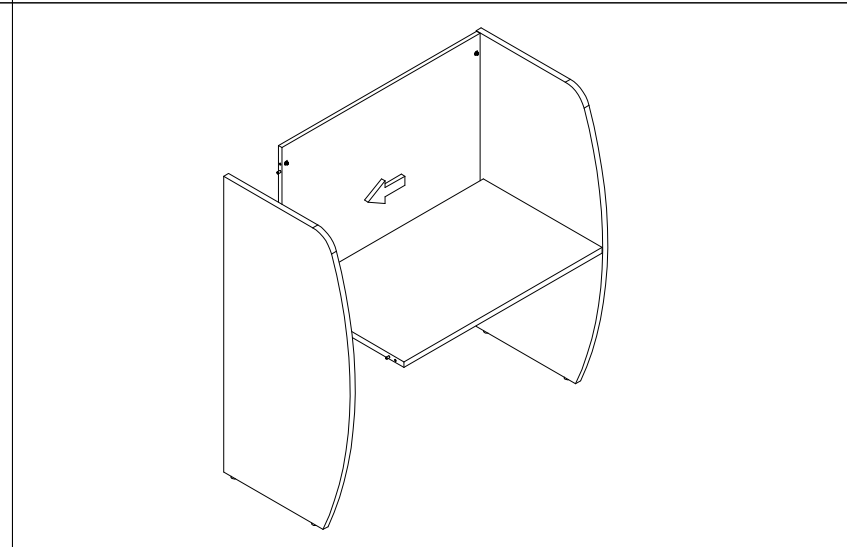
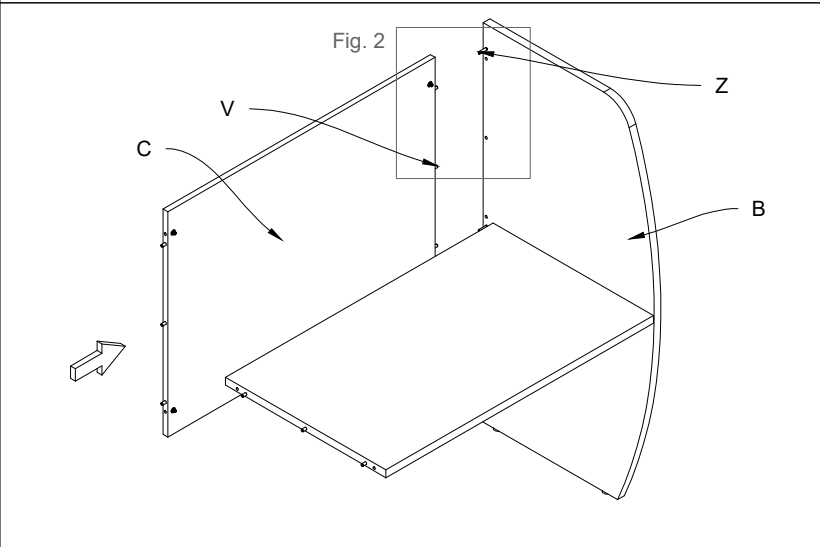
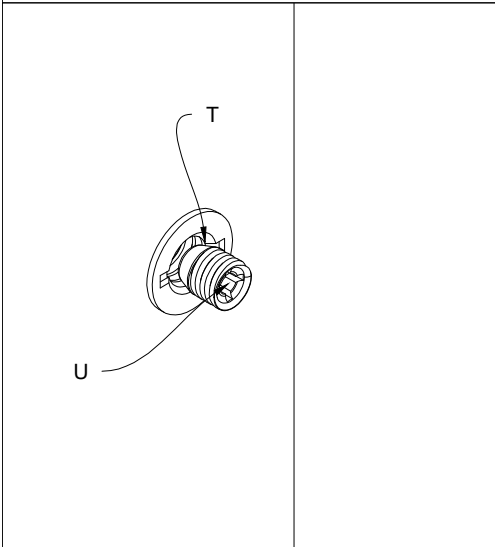

Fig.1 Unire l'allungo call con il call autonomo tramite i tiranti (Z) e le spine (V)
 Fig.1 Unite the extension Call to the independent Call by means of the tie-rods (Z) and wooden pins (V)

5) Unire l'allungo call con il call autonomo tramite i tiranti e le spine (V).
 5) Unite the extension Call to the independent Call by means of the tie-rods (Z) and wooden pins (V)

6) Inserire il fianco finale del call autonomo tramite tiranti e spine (V).
 6) Insert the last side of the independent Call by means of the tie-rods and wooden pins (V)

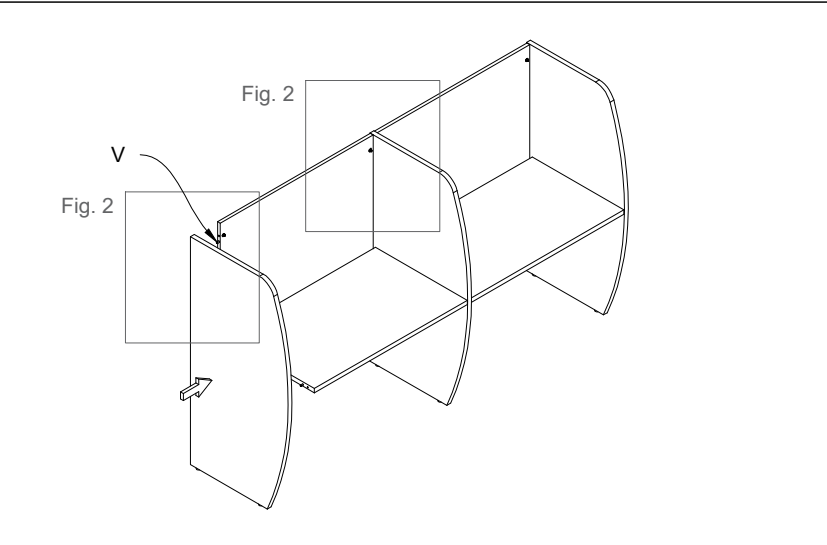
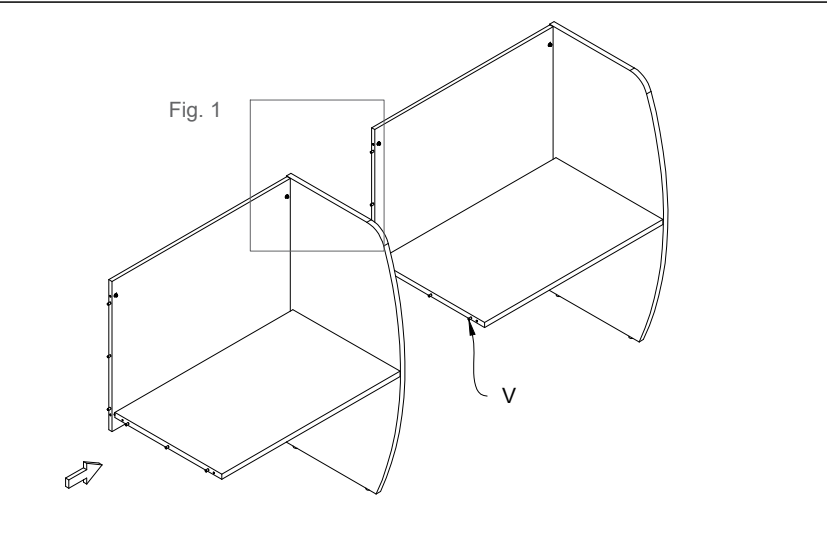
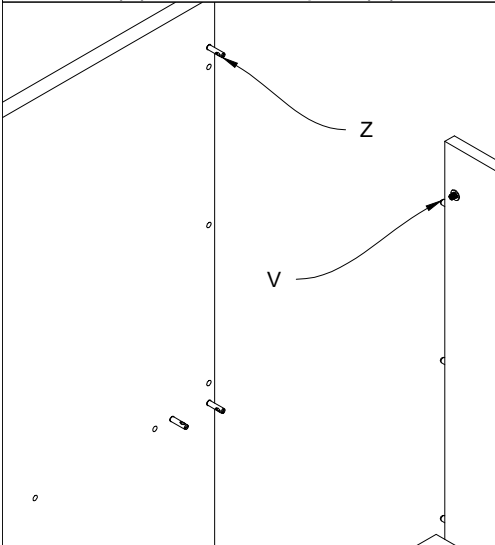

Fig.2 Serrare i grani (U) nei barilotti (T)
 Fig.2 Tighten the threaded screws (U) in the barrels (T)

