

# Schema di montaggio Assembly diagram







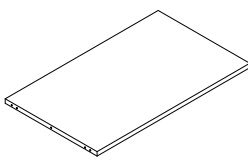
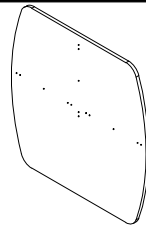
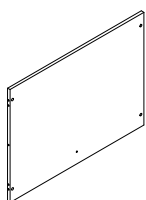

Ferramenta Hardware	Componenti Components		Piani (A) Tops (A)		Fianco intermedio (B) Intermediate side (B)		Frontale (C) Frontal panel (C)		
Bullone 4x16 (Q) 	Bolt 4x16 (Q) <b>n°8</b>								
Staffa a "L" (R) 	"L" shaped bracket (R) <b>n°2</b>								
Piedini diam. 35 (S) 	Feet diam. 35 (S) <b>n°2</b>								
Bariotto 14x14 (T) 	Barrel 14x14 (T) <b>n°12</b>								
Grano 8x8 (U) 	Threaded screw 8x8 (U) <b>n°12</b>								
Spina 8x30 (V) 	Wooden pin 8x30 (V) <b>n°18</b>								
Tirante 7x33.5 (Z) 	Tie-rod 7x33.5 (Z) <b>n°12</b>								
Chiave esagonale 	Hexagonal key <b>n°1</b>								
									

Fig.1 Inserimento dei tiranti (Z) nel fianco (B)

Fig.1 Insert the tie-rods (Z) in the side (B)

1) Posizionare i tiranti (Z) e i piedini (S) nel fianco (B)

1) Position the tie-rods (Z) and feet (S) in the side (B)

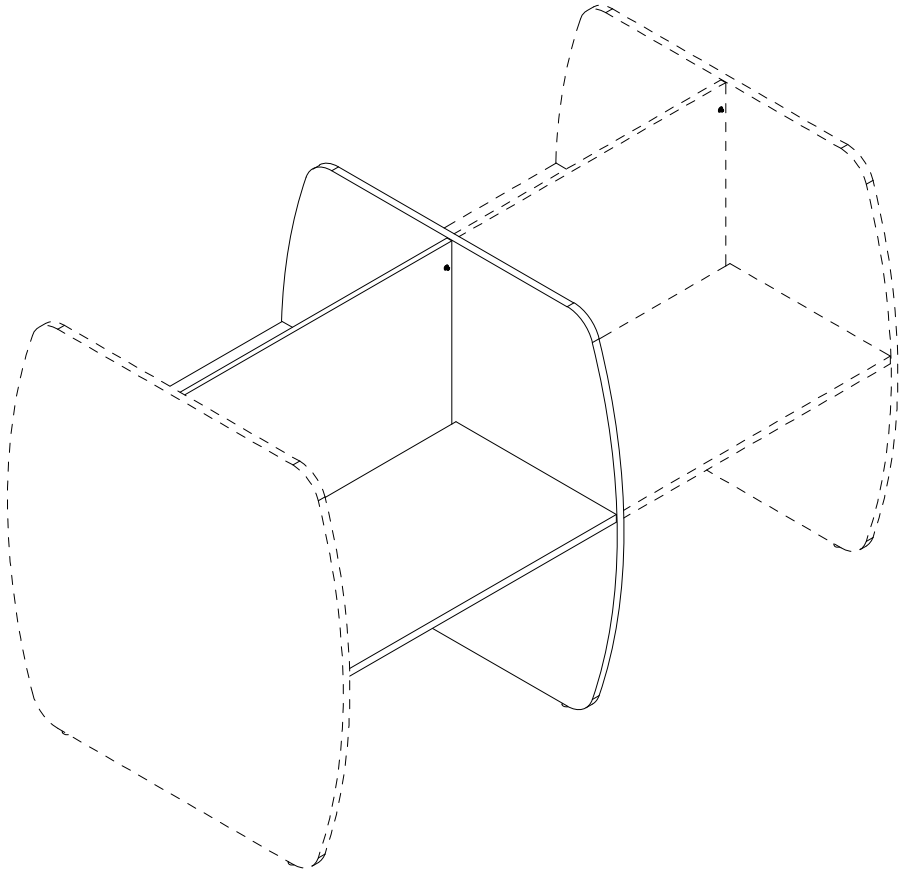
2) Inserire i piani (A) nel fianco (B) tramite i tiranti (Z) e spine (V)

2) Insert the tops (A) in the side (B) by means of the tie-rods (Z) and wooden pins (V)

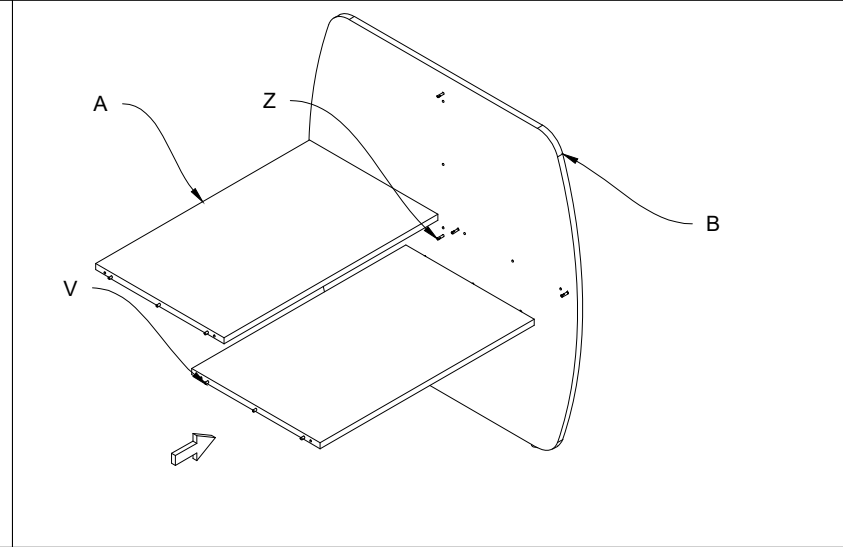
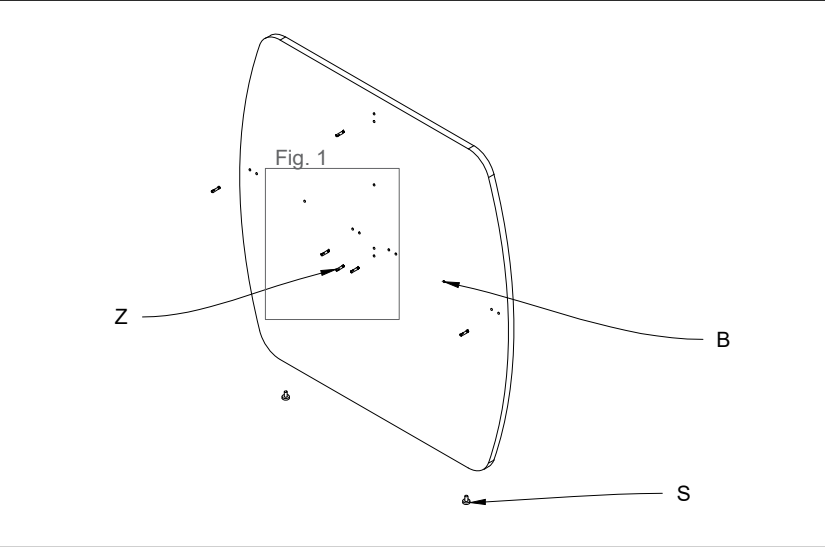
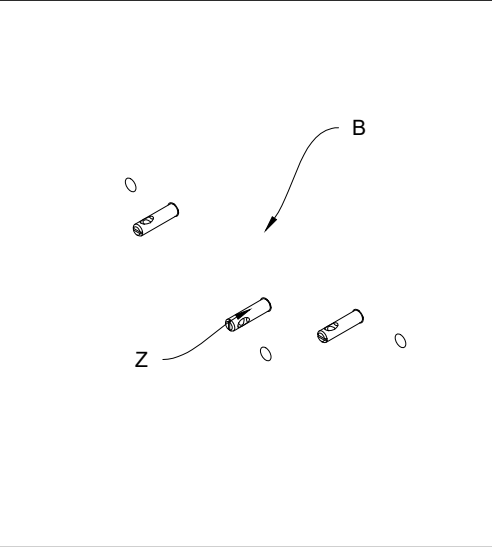

Fig.2 Serrare i grani (U) nei barilotti (T)

Fig.2 Tighten the threaded screws (U) in the barrels (T)

3) Inserire il frontale (C) nel fianco (B) tramite i tiranti (Z) e spine (V).

3) Insert the frontal panel (C) in the side (B) by means of the tie-rods (Z) and wooden pins (V)

4) Separare il fianco esterno dal call autonomo.

4) Separate the side from the independent Call

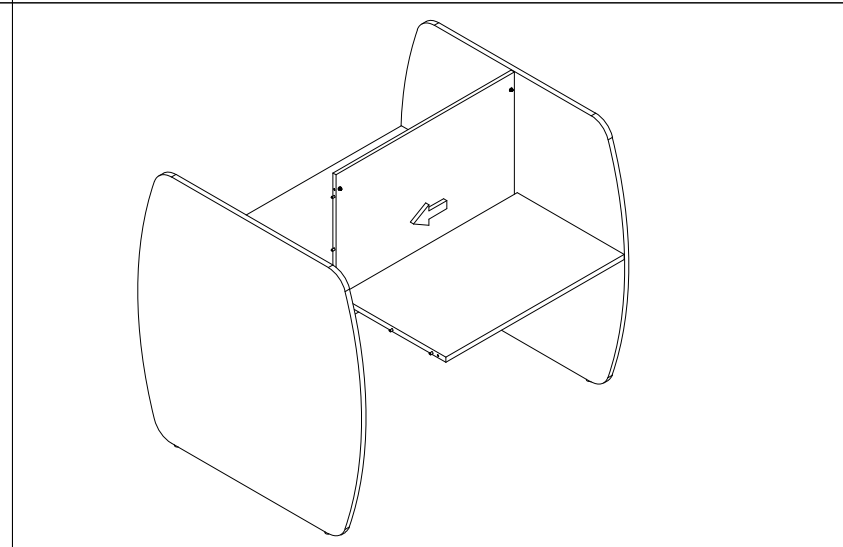
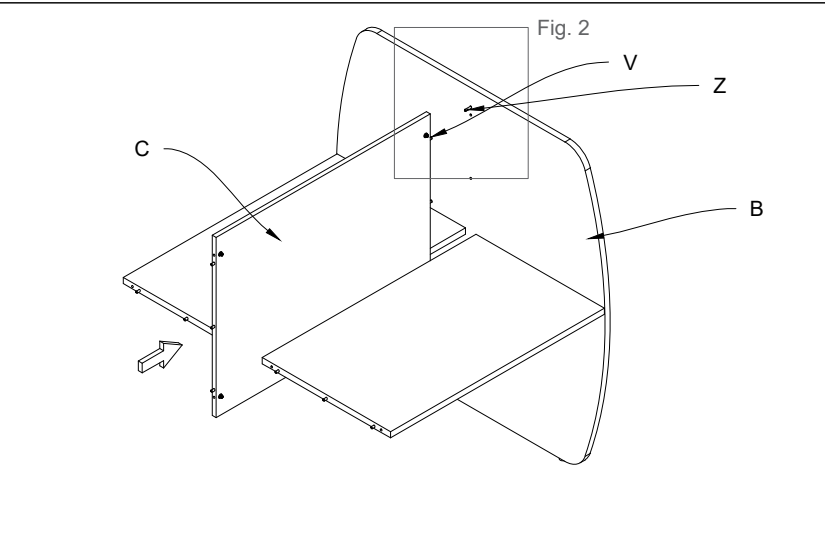
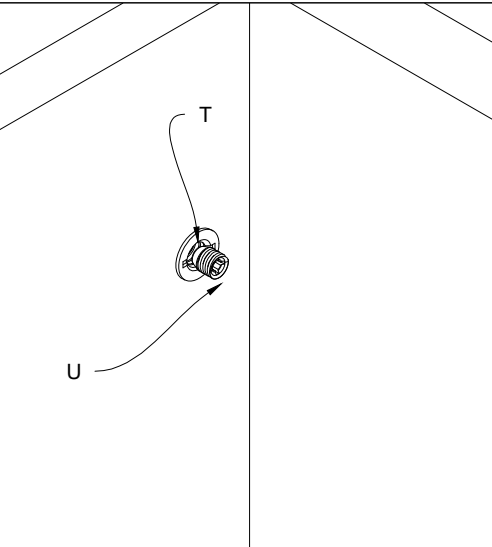
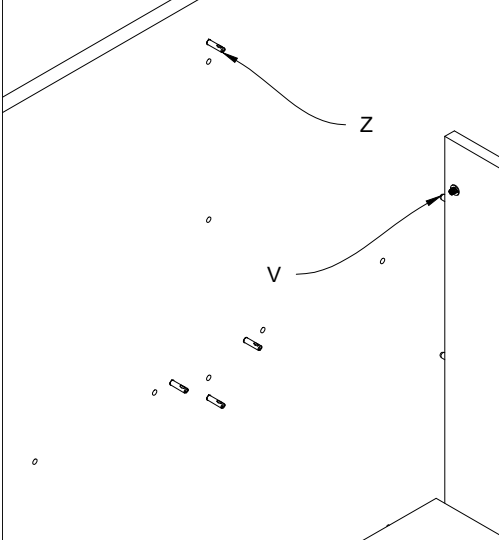
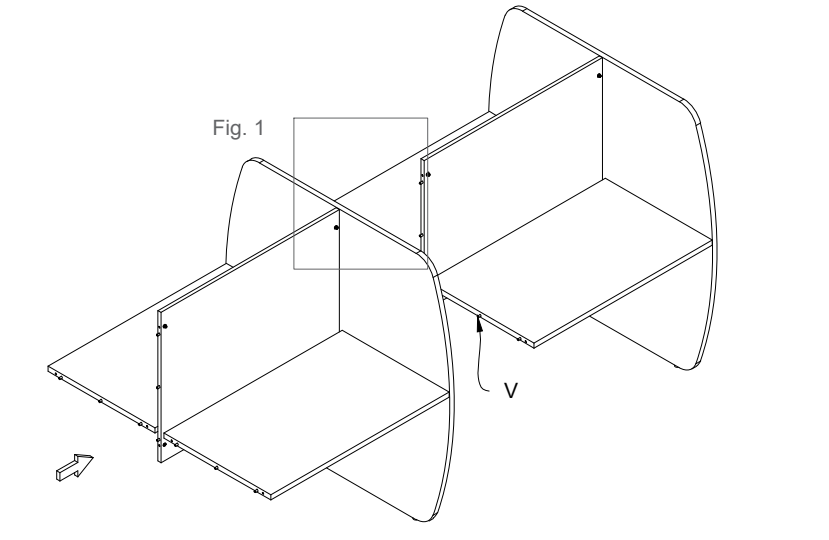

Fig.1 Unire l'allungo call con il call autonomo tramite i tiranti (Z) e le spine (V)  
Fig.1 Unite the extension Call to the independent Call by means of the tie-rods (Z) and wooden pins (V)



5) Unire l'allungo call con il call autonomo tramite i tiranti e le spine (V).  
5) Unite the extension Call to the independent Call by means of the tie-rods and wooden pins (V)



6) Inserire il fianco finale del call autonomo tramite tiranti e spine (V).  
6) Insert the last side of the independent Call by means of the tie-rods and wooden pins (V)

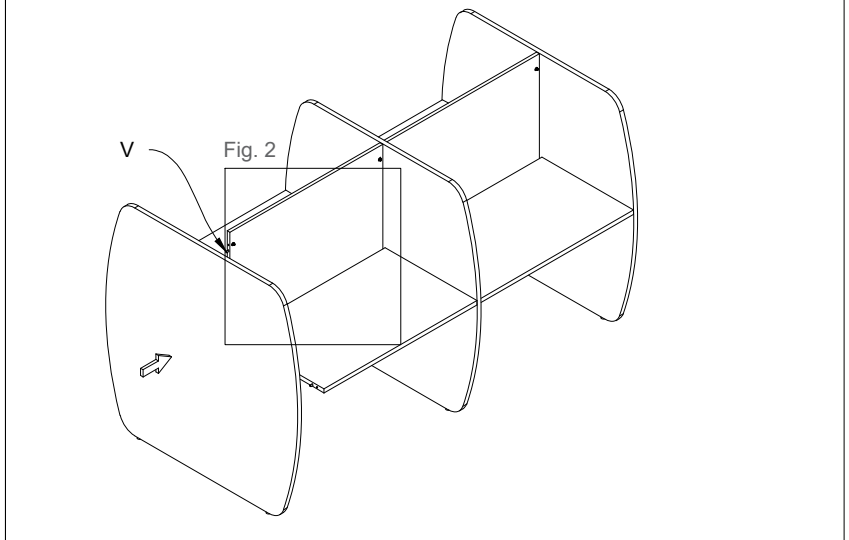

Fig.2 Posizionare la staffa a "L" (R) tra il frontale (C) e il piano (A) e serrare i bulloni (Q).  
Fig.2 Position the "L" shaped bracket (R) between the frontal panel (C) and top (A), tighten the bolts (Q)

