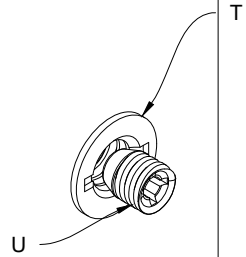



Fig.1 Serrare i grani (U) nei barilotti (T)

Fig.1 Tighten the threaded screws (U) in the barrels (T)



1) Posizionare i tiranti (Z) e i piedini (S) in un fianco (B)

1) Position the tie-rods (Z) and feet (S) in the side (B)

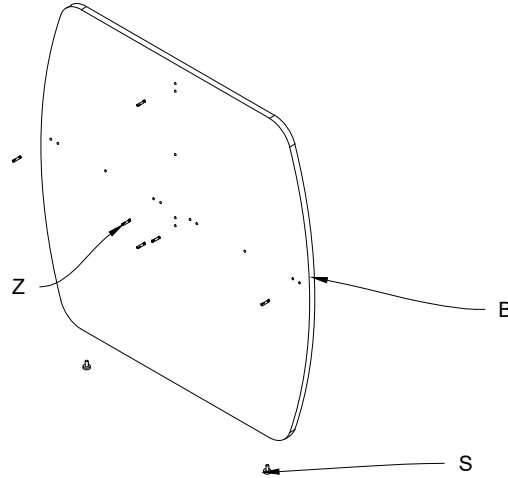

2) Inserire i piani (A) nel fianco (B) tramite i tiranti (Z) e spine (V)

2) Insert the tops (A) in the side (B) by means of the tie-rods (Z) and wooden pins (V)

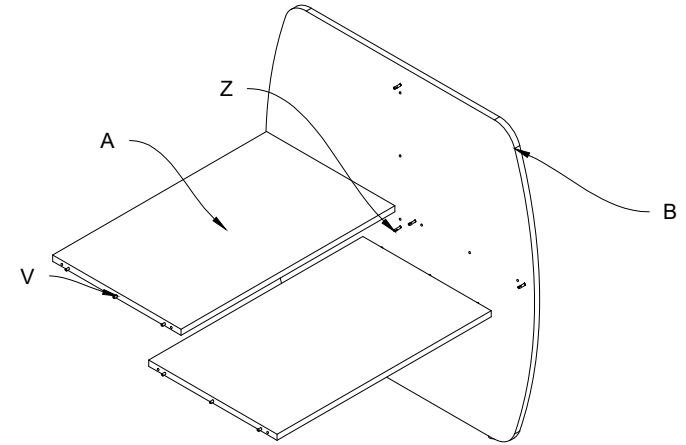
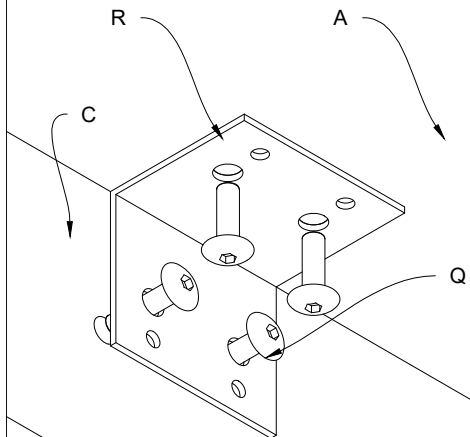

Fig.2 Posizionare la staffa a "L" (R) tra il frontale (C) e il piano (A) e serrare i bulloni (Q).

Fig.2 Position the "L" shaped bracket (R) between the frontal panel (C) and top (A), tighten the bolts (Q)



3) Inserire il frontale (C) nel fianco (B) tramite i tiranti (Z) e spine (V).

3) Insert the frontal panel (C) in the side (B) by means of the tie-rods (Z) and wooden pins (V)

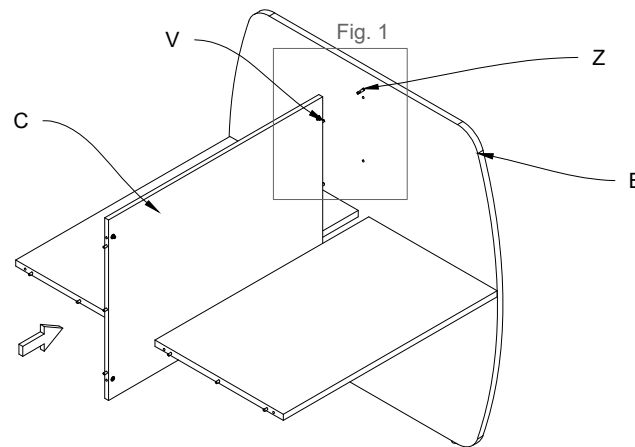

4) Inserire il secondo fianco (B) nel piano (A) e nel frontale (C) tramite i tiranti e le spine (V).

4) Insert the second side (B) in the top (A) and frontal panel (C) by means of the tie-rods (Z) and wooden pins (V)

