

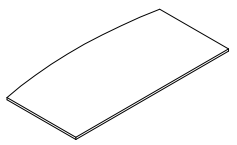

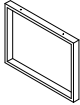

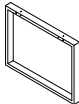





| Ferramenta<br>Hardware                    | Componenti<br>Components |  | Piano (A)<br>Top (A)  |   | Gamba (B)<br>Leg (B)  |   | Travi (C)<br>Crossbar (C) |  |  |
|---|--------------------------|--|---|---|---|---|---------------------------|--|--|
| Chiave esagonale<br>Hexagonal key         | n°1                      |   |  |  |  |  |                           |  |  |
| Distanziale (N)<br>Spacer (N)             | n°4                      |    |   |   |   |   |                           |  |  |
| Paracolpo (O)<br>Strut (O)                | n°4                      |   |   |   |   |   |                           |  |  |
| Piedini diam. 35 (P)<br>Feet diam. 35 (P) | n°4                      |   |   |   |   |   |                           |  |  |
| Rondella sp.16 (Q)<br>Washer sp.16 (Q)    | n°4                      |    |   |   |   |   |                           |  |  |
| Dado 6 MA (S)<br>Nut 6 MA (S)             | n°4                      |   |   |   |   |   |                           |  |  |
| Bullone 6x16 (T)<br>Bolt 6x16 (T)         | n°4                      |  |   |   |   |   |                           |  |  |
| Bullone 6x20 (U)<br>Bolt 6x20 (U)         | n°24                     |  |   |   |   |   |                           |  |  |
| Bullone 6x45 (V)<br>Bolt 6x45 (V)         | n°4                      |  |   |   |   |   |                           |  |  |
| Bullone 6x60 (Z)<br>Bolt 6x60 (Z)         | n°4                      |  |   |   |   |   |                           |  |  |
|   |                          |  |   |   |   |   |                           |  |  |



**Fig.1 Fissare i bulloni (U) nei distanziali (N) delle gambe (B)**

**Fig.1 Fasten the bolts (U) in the spacers (N) of the legs (B)**

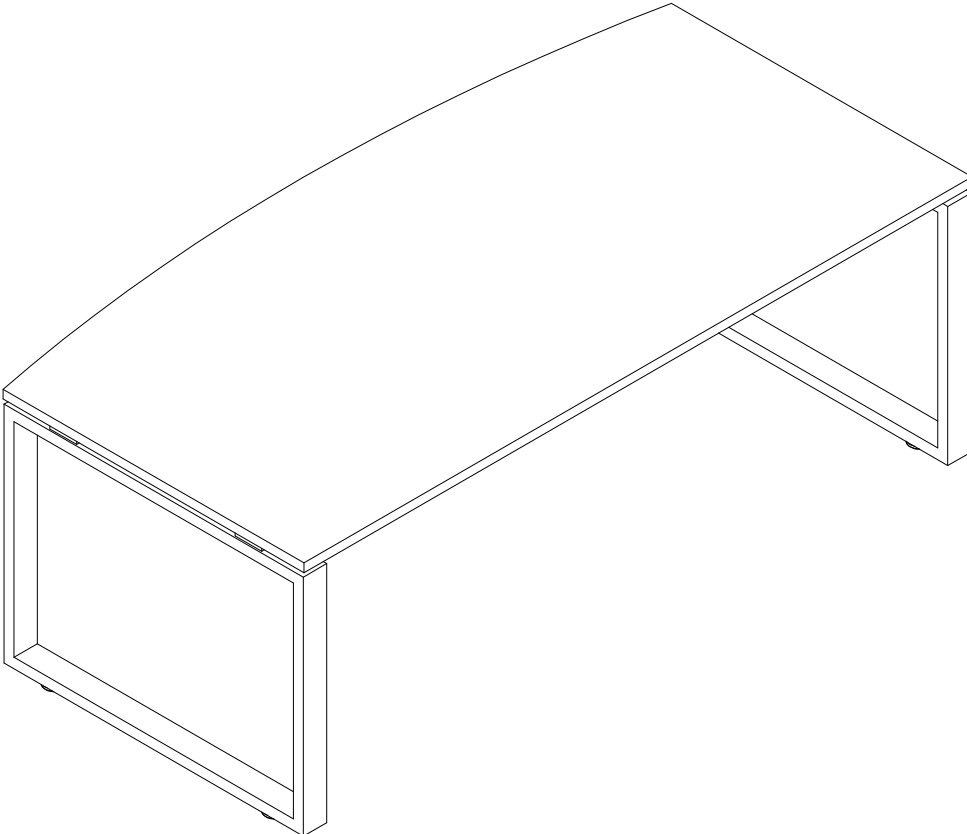
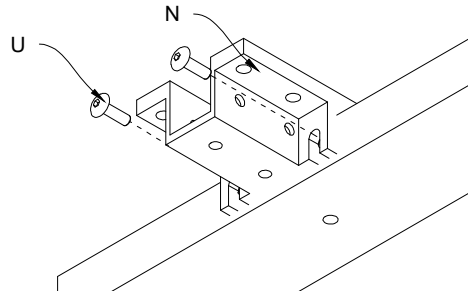

**1) Posizionare i distanziali (N) e i piedini (P), nelle gambe (B)**

**1) Position the spacer (N) and feet (P), in the legs (B)**

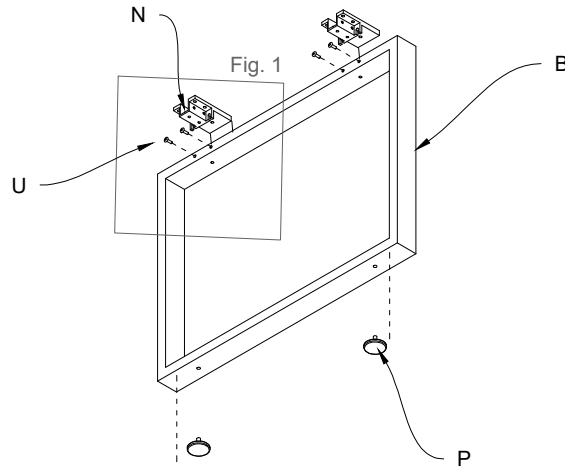

**2) Posizionare le travi (C) sulle gambe (B) ed inserire i paracolpi (O) .**

**2) Position the crossbar (C) on the legs (B) and insert the struts (O)**

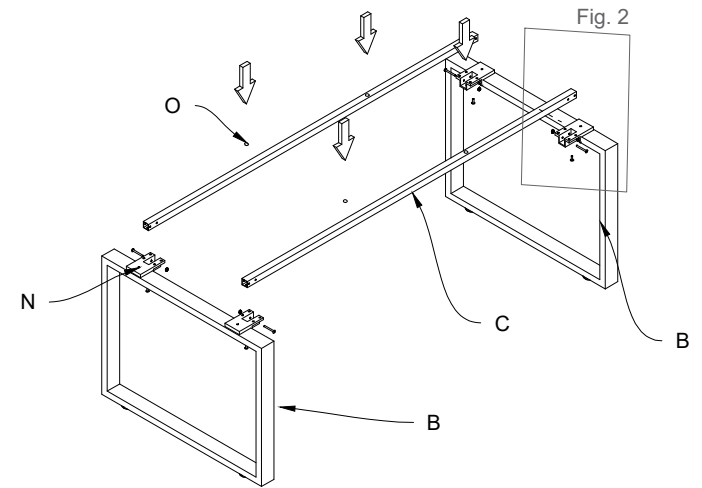

**Fig.2 Fissare i bulloni (V e T) nei distanziali (N) con un dado (S) e rondelle (Q), nella struttura**

**Fig.2 Fasten the bolts (V and T) to the spacers (N) with one nut (S) and washer (Q) on structure**

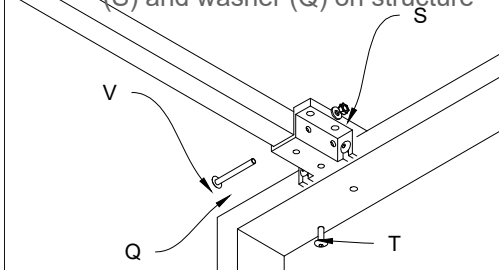

**3) Posizionare il piano (A) sopra la struttura.**

**3) Position the top (A) on top of the structure.**

**Fig.3 Fissare i bulloni (U e Z) nei distanziali con il piano e la struttura**

**Fig.3 Fasten the bolts (U and Z) to the spacers in the top and structure**

