

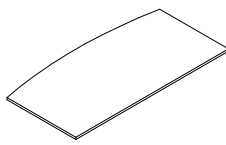

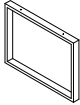

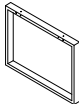





Ferramenta Hardware	Componenti Components		Piano (A) Top (A)		Gamba (B) Leg (B)		Travi (C) Crossbar (C)		
Chiave esagonale Hexagonal key	n°1								
Distanziale (N) Spacer (N)	n°4								
Paracolpo (O) Strut (O)	n°4								
Piedini diam. 35 (P) Feet diam. 35 (P)	n°4								
Rondella sp.16 (Q) Washer sp.16 (Q)	n°4								
Dado 6 MA (S) Nut 6 MA (S)	n°4								
Bullone 6x16 (T) Bolt 6x16 (T)	n°4								
Bullone 6x20 (U) Bolt 6x20 (U)	n°24								
Bullone 6x45 (V) Bolt 6x45 (V)	n°4								
Bullone 6x60 (Z) Bolt 6x60 (Z)	n°4								

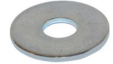
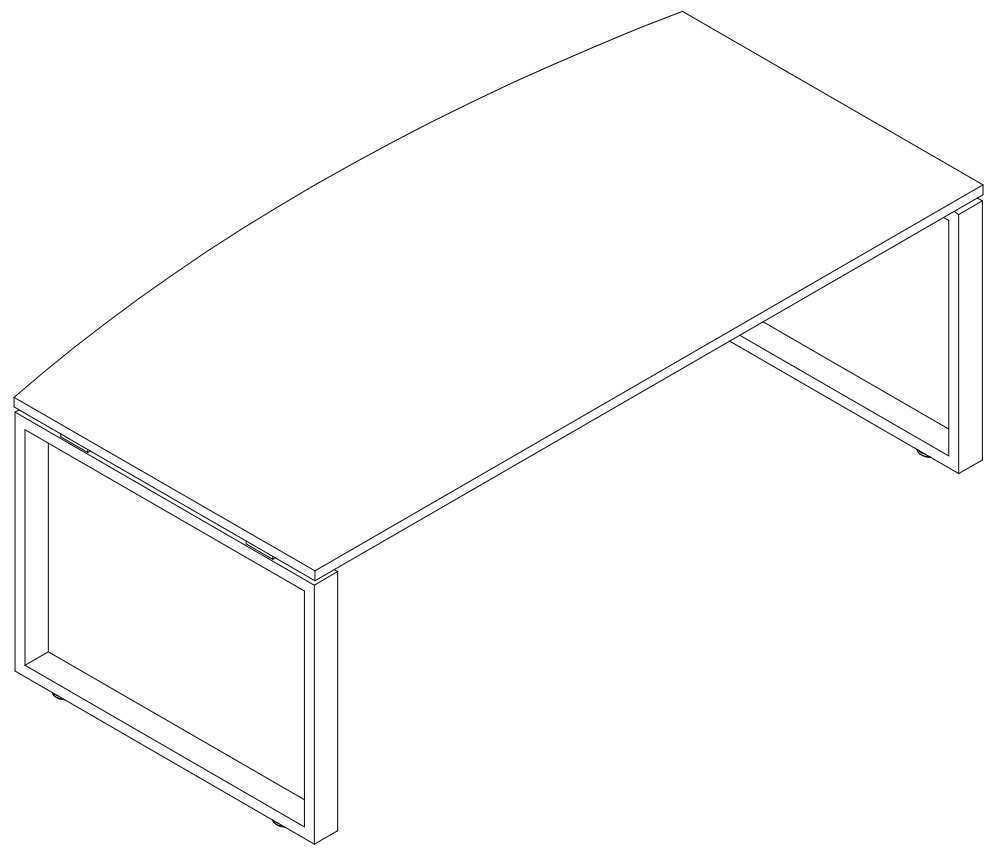
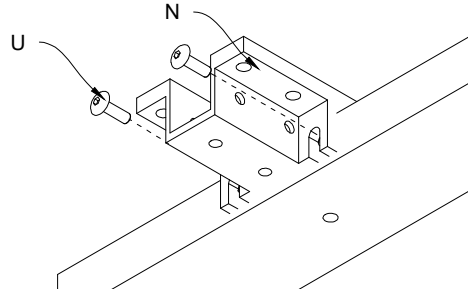

Fig.1 Fissare i bulloni (U) nei distanziali (N) delle gambe (B)

Fig.1 Fasten the bolts (U) in the spacers (N) of the legs (B)



1) Posizionare i distanziali (N) e i piedini (P), nelle gambe (B)

1) Position the spacer (N) and feet (P), in the legs (B)

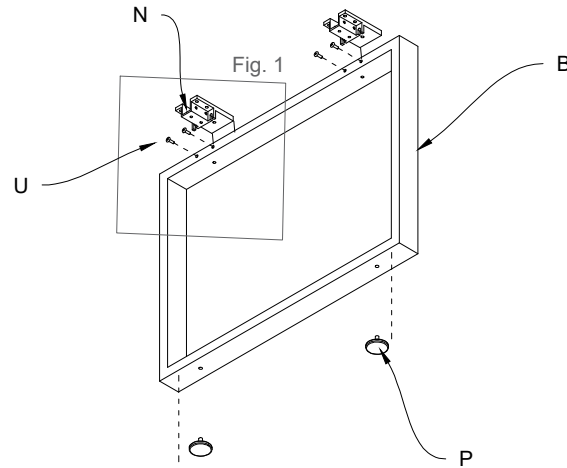

2) Posizionare le travi (C) sulle gambe (B) ed inserire i paracolpi (O) .

2) Position the crossbar (C) on the legs (B) and insert the struts (O)

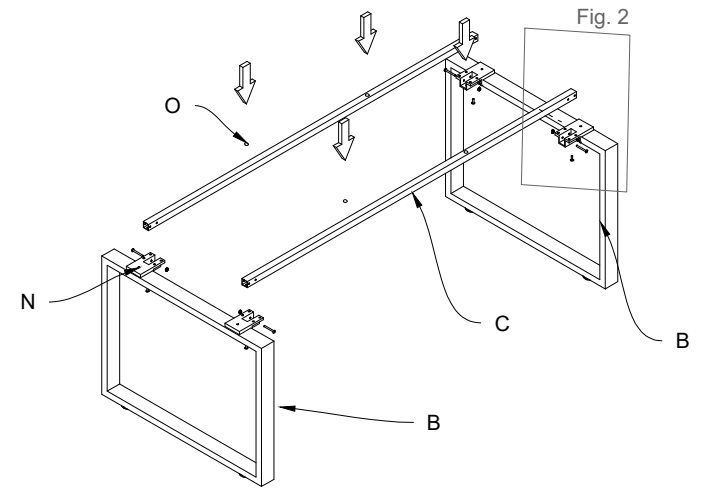
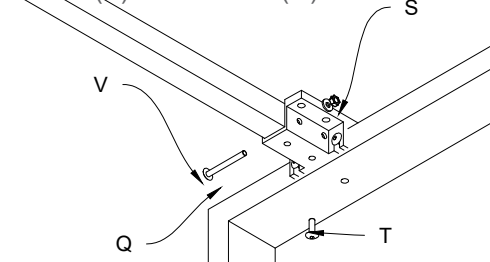

Fig.2 Fissare i bulloni (V e T) nei distanziali (N) con un dado (S) e rondelle (Q), nella struttura

Fig.2 Fasten the bolts (V and T) to the spacers (N) with one nut (S) and washer (Q) on structure



3) Posizionare il piano (A) sopra la struttura.

3) Position the top (A) on top of the structure.

Fig.3 Fissare i bulloni (U e Z) nei distanziali con il piano e la struttura

Fig.3 Fasten the bolts (U and Z) to the spacers in the top and structure

